

# PLASMA CLEANER

PDC-001-HP (115V) / PDC-002-HP (230V) HIGH EXPANDED PLASMA CLEANER  
USER MANUAL

PDC-VCG (115V) / PDC-VCG-2 (230V)  
VACUUM GAUGE & DIGITAL METER (OPTIONAL)

PDC-FMG (115V) / PDC-FMG-2 (230V) PLASMAFLO (OPTIONAL)



---

**HARRICK PLASMA**

120 Brindley St. • Ithaca, NY 14850  
(USA) 800-640-6380 • (Intl) 607-272-5070  
[www.harrickplasma.com](http://www.harrickplasma.com)





# CHINA ROHS DECLARATION 中国RoHS认证



## HARRICK PLASMA PDC-002-HP HIGH POWER EXPANDED PLASMA CLEANER

### HARRICK 等离子清洗机 PDC-002-HP

#### TABLE OF HAZARDOUS SUBSTANCES

#### 有害物质表

Part Name 部件名称	Lead (Pb) 铅及其化合物	Mercury (Hg) 汞及其化合物	Cadmium (Cd) 镉及其化合物	Hexavalent Chromium (Cr) 六价铬化合物	Polybrominated biphenyls (PBB) 多溴联苯	Polybrominated diphenyl Ethers (PBDE) 多溴二苯醚
Metal Chassis and Panels 金属机架和面板	O	O	O	O	O	O
Metal Fasteners 金属扣件	O	O	O	O	O	O
Metal Support Parts 金属支持部件	X	O	O	O	O	O
Plastic Support Parts 塑料支持部件	O	O	O	O	O	O
Wire Assemblies, Cables, and Connectors 金属丝组件, 电缆和连接器	O	O	O	O	O	O
Printed Circuit Board (PCB) Assembly 印刷电路板组件	X	O	O	O	O	O
Vacuum Tubes 真空管	X	O	O	O	O	O
Power Supply 电源	O	O	O	O	O	O
Transformer 变压器	O	O	O	O	O	O
Chamber 舱室	O	O	O	O	O	O
Valve Assembly 气门组件	O	O	O	O	O	O
Fluorescent Bulb (accessory) 荧光灯 (附件)	O	X	O	O	O	O

This table is created in accordance with SJ/T 11364-2014 standard.

本表格依据SJ/T 11364-2014的规定编制。

O : Indicates that the concentration of this hazardous substance in all the homogenous materials for this part is below the relevant threshold of the GB/T 26572-2011 standard.

O : 表示该有害物质在该部件所有均质材料中的含量均在GB/T 26572-2011 规定的限量要求以下。

X : Indicates that the concentration of the hazardous substance of at least one of all homogeneous materials in the parts is above the relevant threshold of the GB/T 26572-2011 standard, but is exempt from EU RoHS Directive 2011/65/EU.

X : 表示该有害物质在该部件所有均质材料中的含量在GB/T 26572-2011 规定的限量要求以上, 但受免于欧盟RoHS 2011/65/EU 的指令。

### ENVIRONMENT-FRIENDLY USE PERIOD (EFUP)

#### 环保使用期限 (EFUP)

The Environment-Friendly Use Period (EFUP) of this product is 20 years.

该产品的环保使用期限为20年。

In accordance with the requirements of China's Management Methods for the Restriction of the Use of Hazardous Substances in Electrical and Electronic Products, the EFUP is the period in years during which the hazardous substances contained in this product will not leak nor mutate under normal use and operating conditions. The normal use and operating conditions have been defined in the product user manual distributed with this product. There is no guarantee that the product will remain free from defects for the duration of the EFUP. The EFUP has no effect on product life, warranties, terms or conditions associated with the sale of this product.

根据中国对电子产品和电子产品中有害物质使用限制的管理方法的要求, 该产品所含的有害物质在正常使用和操作条件下不会发生泄漏或发生突变。产品用户手册中已经定义了正常使用和操作条件。在环保使用期限的持续时间里, 不能保证产品不会有缺陷。环保使用期限对产品寿命、保修条款、其他条款或条件以及销售没有影响。



# CHINA ROHS DECLARATION

## 中国RoHS认证



### HARRICK PLASMA PDC-FMG-2 PLASMAFLO GAS FLOW MIXER

### HARRICK 气体混合器PDC-FMG-2

#### TABLE OF HAZARDOUS SUBSTANCES

#### 有害物质表

Part Name 部件名称	Lead (Pb) 铅及其化合物	Mercury (Hg) 汞及其化合物	Cadmium (Cd) 镉及其化合物	Hexavalent Chromium (Cr) 六价铬化合物	Polybrominated biphenyls (PBB) 多溴联苯	Polybrominated diphenyl Ethers (PBDE) 多溴二苯醚
Metal Chassis and Panels 金属机架和面板	O	O	O	O	O	O
Metal Fasteners 金属扣件	O	O	O	O	O	O
Metal Gas Tubing and Fittings 金属燃气管道及配件	O	O	O	O	O	O
Wire Assemblies, Cables, and Connectors 金属丝组件, 电缆和连接器	X	O	O	O	O	O
Flowmeters 流量计	O	O	O	O	O	O
Vacuum Gauge Tube Sensor 真空规管传感器	O	O	O	O	O	O
Vacuum Gauge Cable 真空计电缆	O	O	O	O	O	O
Vacuum Digital Meter Display and Printed Circuit Board (PCB) Assembly 真空数字仪表显示器和印刷电路板(PCB)组件	O	O	O	O	O	O
Power Supply and Power Entry Module 电源及电源输入模块	O	O	O	O	O	O

This table is created in accordance with SJ/T 11364-2014 standard.

本表格依据SJ/T 11364-2014的规定编制。

O : Indicates that the concentration of this hazardous substance in all the homogenous materials for this part is below the relevant threshold of the GB/T 26572-2011 standard.

O : 表示该有害物质在该部件所有均质材料中的含量均在GB/T 26572-2011 规定的限量要求以下。

X : Indicates that the concentration of the hazardous substance of at least one of all homogeneous materials in the parts is above the relevant threshold of the GB/T 26572-2011 standard, but is exempt from EU RoHS Directive 2011/65/EU.

X : 表示该有害物质在该部件所有均质材料中的含量在GB/T 26572-2011 规定的限量要求以上, 但受免于欧盟RoHS 2011/65/EU 的指令。

### ENVIRONMENT-FRIENDLY USE PERIOD (EFUP)

### 环保使用期限 (EFUP)

The Environment-Friendly Use Period (EFUP) of this product is 20 years.

该产品的环保使用期限为20年。

In accordance with the requirements of China's Management Methods for the Restriction of the Use of Hazardous Substances in Electrical and Electronic Products, the EFUP is the period in years during which the hazardous substances contained in this product will not leak nor mutate under normal use and operating conditions. The normal use and operating conditions have been defined in the product user manual distributed with this product. There is no guarantee that the product will remain free from defects for the duration of the EFUP. The EFUP has no effect on product life, warranties, terms or conditions associated with the sale of this product.

根据中国对电子产品和电子产品中有害物质使用限制的管理方法的要求, 该产品所含的有害物质在正常使用和操作条件下不会发生泄漏或发生突变。产品用户手册中已经定义了正常使用和操作条件。在环保使用期限的持续时间里, 不能保证产品不会有缺陷。环保使用期限对产品寿命、保修条款、其他条款或条件以及销售没有影响。



# CHINA ROHS DECLARATION

## 中国RoHS认证



### HARRICK PLASMA PDC-VCG-2 VACUUM GAUGE AND DIGITAL METER

### HARRICK 真空监测单元 PDC-VCG-2

#### TABLE OF HAZARDOUS SUBSTANCES

#### 有害物质表

Part Name 部件名称	Lead (Pb) 铅及其化合物	Mercury (Hg) 汞及其化合物	Cadmium (Cd) 镉及其化合物	Hexavalent Chromium (Cr) 六价铬化合物	Polybrominated biphenyls (PBB) 多溴联苯	Polybrominated diphenyl Ethers (PBDE) 多溴二苯醚
Metal Chassis and Panels 金属机架和面板	O	O	O	O	O	O
Metal Fasteners 金属扣件	O	O	O	O	O	O
Wire Assemblies, Cables, and Connectors 金属丝组件, 电缆和连接器	X	O	O	O	O	O
Vacuum Gauge Tube Sensor 真空规管传感器	O	O	O	O	O	O
Vacuum Gauge Cable 真空计电缆	O	O	O	O	O	O
Vacuum Digital Meter Display and Printed Circuit Board (PCB) Assembly 真空数字仪表显示器和印刷电路板 (PCB) 组件	O	O	O	O	O	O
Power Supply and Power Entry Module 电源及电源输入模块	O	O	O	O	O	O

This table is created in accordance with SJ/T 11364-2014 standard.

本表格依据SJ/T 11364-2014的规定编制。

O : Indicates that the concentration of this hazardous substance in all the homogenous materials for this part is below the relevant threshold of the GB/T 26572-2011 standard.

O : 表示该有害物质在该部件所有均质材料中的含量均在GB/T 26572-2011 规定的限量要求以下。

X : Indicates that the concentration of the hazardous substance of at least one of all homogeneous materials in the parts is above the relevant threshold of the GB/T 26572-2011 standard, but is exempt from EU RoHS Directive 2011/65/EU.

X : 表示该有害物质在该部件所有均质材料中的含量在GB/T 26572-2011 规定的限量要求以上, 但受免于欧盟RoHS 2011/65/EU 的指令。

### ENVIRONMENT-FRIENDLY USE PERIOD (EFUP)

### 环保使用期限 (EFUP)

The Environment-Friendly Use Period (EFUP) of this product is 20 years.

该产品的环保使用期限为20年。

In accordance with the requirements of China's Management Methods for the Restriction of the Use of Hazardous Substances in Electrical and Electronic Products, the EFUP is the period in years during which the hazardous substances contained in this product will not leak nor mutate under normal use and operating conditions. The normal use and operating conditions have been defined in the product user manual distributed with this product. There is no guarantee that the product will remain free from defects for the duration of the EFUP. The EFUP has no effect on product life, warranties, terms or conditions associated with the sale of this product.

根据中国对电子产品和电子产品中有害物质使用限制的管理方法的要求, 该产品所含的有害物质在正常使用和操作条件下不会发生泄漏或发生突变。产品用户手册中已经定义了正常使用和操作条件。在环保使用期限的持续时间里, 不能保证产品不会有缺陷。环保使用期限对产品寿命、保修条款、其他条款或条件以及销售没有影响。

**General Information**

Safety Information and Unpacking .....	1
Technical Support and Feedback .....	1

**Plasma Treatment Overview**

Nature of Plasma and Plasma Formation .....	2
Plasma-Surface Interactions .....	2
Types of Plasma-Surface Interactions .....	2
Plasma Processing .....	3

**About the Vacuum Pump**

Vacuum Pump Requirements .....	4
Guidelines for Setting Up the Vacuum Pump .....	4
Setting Up the Vacuum Pump .....	6

**About the Plasma Cleaner**

Parts of the Plasma Cleaner .....	8
Setting Up the Plasma Cleaner .....	10

**About the Optional PDC-VCG / PDC-VCG-2 Vacuum Gauge and Digital Meter**

Parts of the Vacuum Gauge and Digital Meter .....	12
Setting Up the Vacuum Gauge and Digital Meter .....	14

**About the Optional PDC-FMG / PDC-FMG-2 PlasmaFlo**

Parts of the PlasmaFlo .....	16
Setting Up the PlasmaFlo .....	19

**Connecting the Process Gas Cylinder**

Guidelines for Setting Up the Gas Cylinder .....	20
Connecting the Gas Directly to the Plasma Cleaner .....	21
Connecting the Gas to the PlasmaFlo .....	22

**Plasma Processing**

Guidelines for Plasma Processing .....	25
Processing with Air or Gas Connected Directly to the Plasma Cleaner .....	26
Processing with Gas Using the PlasmaFlo .....	30

**Purging Reactive Gases from the Plasma Cleaner**

Connecting the Inert Gas for Purging .....	32
Purging with Inert Gas after Plasma Treatment (Gas Connected Directly to the Plasma Cleaner) .....	33
Purging with Inert Gas after Plasma Treatment (Using the PlasmaFlo) .....	34



## TABLE OF CONTENTS

<b>Maintenance</b>	
Maintenance Requirements .....	36
Cleaning the Chamber .....	36
Replacing the Chamber .....	36
Cleaning the Plasma Cleaner Door and O-Ring .....	38
Replacing the Window and Window O-Ring .....	39
Checking and Replacing the Fuses .....	40
<b>Troubleshooting</b> .....	42
<b>Warranty Information</b>	
Disclaimer and Warranty .....	44
Repair Returns and New Equipment Returns .....	44
<b>Specifications</b>	
PDC-001-HP / PDC-002-HP High Power Expanded Plasma Cleaner .....	45
PDC-VCG / PDC-VCG-2 Vacuum Gauge and Digital Meter .....	45
PDC-FMG / PDC-FMG-2 PlasmaFlo .....	46
Standard Vacuum Pumps: PDC-VPE / PDC-VPE-2 (for air and inert gases) .....	46
Oxygen Service Pumps: PDC-OPD / PDC-OPD-2, PDC-OPE / PDC-OPE-2 (for oxygen (O <sub>2</sub> ) gas) .....	47
<b>Appendix A</b>	
Flowrate Table for PlasmaFlo Flowmeter 1 and Flowmeter 2 (032-15) .....	48
<b>Appendix B</b>	
Available Vacuum Pumps, Optional Accessories, Replacement Parts and Fuses.....	49

<b>Figure 1</b> • Example Vacuum Pumps and Accessories .....	5
<b>Figure 2</b> • Setting Up an Example Vacuum Pump .....	7
<b>Figure 3</b> • PDC-001-HP High Power Expanded Plasma Cleaner (115V) .....	8
<b>Figure 4</b> • PDC-002-HP High Power Expanded Plasma Cleaner (230V) .....	9
<b>Figure 5</b> • Connecting the Metering Valve/3-Way Valve to the Plasma Cleaner Door .....	11
<b>Figure 6</b> • Connecting the Vacuum Hose to the Plasma Chamber Outlet .....	11
<b>Figure 7</b> • PDC-VCG Vacuum Gauge and Digital Meter (115V) .....	12
<b>Figure 8</b> • PDC-VCG-2 Vacuum Gauge and Digital Meter (230V) .....	13
<b>Figure 9</b> • Final Configuration of the Metering Valve, 3-Way Valve, and TC Vacuum Gauge on the Plasma Cleaner Door When Using the Optional PDC-VCG / PDC- VCG-2 or PDC-FMG / PDC-FMG-2 PlasmaFlo .....	15
<b>Figure 10</b> • PDC-FMG PlasmaFlo (115V) .....	16
<b>Figure 11</b> • PDC-FMG-2 PlasmaFlo (230V) .....	17
<b>Figure 12</b> • PlasmaFlo and Accessories .....	18
<b>Figure 13</b> • Setting up the PlasmaFlo Gas Output and Input(s) .....	18
<b>Figure 14</b> • Using the PlasmaFlo with One Gas Source .....	22
<b>Figure 15</b> • Processing with Air or Gas Connected Directly to the Plasma Cleaner .....	24
<b>Figure 16</b> • Example of an Air Plasma .....	27
<b>Figure 17</b> • Processing with Gas Connected to the PlasmaFlo .....	28
<b>Figure 18</b> • Example Configurations for Inert Gas Purge in the Plasma System .....	32
<b>Figure 19</b> • Replacing the Plasma Chamber .....	37
<b>Figure 20</b> • Removing the O-Ring on the Plasma Cleaner Door .....	38
<b>Figure 21</b> • Replacing the Window on the Plasma Cleaner Door .....	39



**SAFETY INFORMATION**

The Plasma Cleaner is designed for safe and efficient operation when used properly and in accordance with this manual. Failure to observe the following precautions could result in serious personal injury:

- ⚠ The Plasma Cleaner is an electrical instrument; to avoid electric shock, please observe all standard precautions, such as not operating the device near water and operating the device at appropriate line voltage and frequency.
- ⚠ Do not remove panels or housing, except by a certified electronics technician.
- ⚠ Do not open the Plasma Cleaner door when the chamber is under vacuum.
- ⚠ Do not use the Plasma Cleaner near flammable materials.
- ⚠ Do not plug vacuum pumps whose input electrical current requirement exceeds 7 Amps into the Plasma Cleaner rear vacuum pump outlet.
- ⚠ With respect to vacuum pumps, please refer to the pump user's manual for specific precautions.
- ⚠ If oxygen is used as the process gas in concentrations near or above its flammability threshold, an oxygen service pump must be used.
- ⚠ If corrosive gases are used, make sure the seals and gas connection materials are compatible with the gas. Use a suitable vacuum pump to service corrosive gases.
- ⚠ If toxic gases or gases that ionize to toxic products or intermediates are used, the gases must be properly purged from the chamber prior to venting and the pump exhaust must be properly vented. For safe gas handling procedures specific to your process gas, contact your process gas supplier.

**UNPACKING**

Before installing the Plasma Cleaner make sure all the parts on the included check-off list are present. If any parts are missing or damaged, contact Harrick Plasma immediately.

**TECHNICAL SUPPORT  
AND FEEDBACK**

Please contact us with questions or comments:

Harrick Plasma  
120 Brindley St.  
Ithaca, NY 14850 USA  
(USA) 800-640-6380  
(Intl) 607-272-5070  
(Fax) 607-272-5076  
[info@harrickplasma.com](mailto:info@harrickplasma.com)

Plasma, the fourth state of matter, is a distinct processing medium for the treatment and modification of surfaces.

### **NATURE OF PLASMA**

- Plasma is a partially ionized gas consisting of electrons, ions and neutral atoms or molecules.
- The plasma electrons are at a much higher temperature than the neutral gas species, typically around  $10^4$  K, although the plasma gas as a whole is at near ambient temperature.
- The plasma electron density is typically  $\sim 10^{10}$  cm<sup>-3</sup>.

### **PLASMA FORMATION**

- A radio frequency (RF) oscillating electric field is generated in the gas region through magnetic induction.
- At sufficiently low pressures the combined effect of the electric field acceleration of electrons and elastic scattering of the electrons with neutral atoms or field lines leads to heating of the electrons.
- When electrons gain kinetic energy in excess of the first ionization threshold in the neutral gas species, electron-neutral collisions lead to further ionization, yielding additional free electrons that are heated in turn.

### **PLASMA-SURFACE INTERACTIONS**

- The energy of plasma electrons and ions is sufficient to ionize neutral atoms, break molecules apart to form reactive radical species, generate excited states in atoms or molecules, and locally heat the surface.
- Depending on the process gases and parameters, plasmas are capable of both mechanical work, through the ablative effect of kinetic transfer of electrons and ions with the surface, and chemical work, through the interaction of reactive radical species with the surface.
- In general, plasmas can interact with and modify a surface through several mechanisms: ablation, chemical etching, activation, deposition, and cross-linking.

### **TYPES OF PLASMA-SURFACE INTERACTIONS**

#### **ABLATION**

- Plasma ablation involves the mechanical removal of surface contaminants by energetic electron and ion bombardment.
- Surface contamination layers are typically comprised of weak C-H bonds.
- Ablation breaks down weak covalent bonds in polymeric contaminants through mechanical bombardment.
- Surface contaminants undergo repetitive chain scission until their molecular weight is sufficiently low for them to boil away in the vacuum.
- Ablation affects only the contaminant layers and the outermost molecular layers of the substrate material.
- Argon is often used for its high ablation efficiency and chemical inertness with the surface material.

**TYPES OF PLASMA-SURFACE INTERACTIONS****CHEMICAL ETCHING**

- Chemical etching involves the chemical reaction of surface organic contaminants with highly reactive free radicals in the plasma to form volatile byproducts that are released from the sample surface.
- By proper selection of the gas chemistry and mixture, various types of materials can be chemically etched. In addition, the material can be selectively etched with minimal etching of other materials on the sample surface.
- Chemical etching involves minimal physical damage or roughening of the sample surface.
- O<sub>2</sub> is often used for chemical etching of organic contaminants from sample surfaces.

**ACTIVATION**

- Plasma surface activation involves the creation of surface chemical functional groups through the use of plasma gases - such as air, oxygen, nitrogen - which dissociate and react with the surface.
- In the case of polymers, surface activation involves the replacement of surface polymer groups with chemical groups from the plasma gas.
- The plasma breaks down weak surface bonds in the polymer and replaces them with highly reactive carbonyl, carboxyl, and hydroxyl groups.
- Such activation alters the chemical activity and characteristics of the surface, such as wetting and adhesion, yielding greatly enhanced adhesive strength and permanency.

**DEPOSITION**

- Plasma deposition involves the formation of a thin polymer coating at the substrate surface through polymerization of the process gas.
- The deposited thin coatings can possess various properties or physical characteristics, depending on the specific gas and process parameters selected.
- Such coatings exhibit a higher degree of cross-linking and much stronger adherence to the substrate in comparison to films derived from conventional polymerization.

**CROSS-LINKING**

- Cross-linking is the covalent bonding of polymer chains to form dense molecular networks.
- Plasma processing with inert gases can be used to cross-link polymers and produce a stronger and harder substrate surface.
- Under certain circumstances, cross-linking through plasma treatment can also lend additional wear or chemical resistance to a material.

**PLASMA PROCESSING**

In general, plasma processing proceeds as follows:

- The sample is placed in the reaction chamber and the chamber is evacuated.
- Process gas(es) are flowed into the chamber to sustain pressures from 300 to 1500 mTorr.
- The process gas is subjected to a MHz-range RF electromagnetic field, creating plasma at near ambient temperature.
- The type of interaction between the plasma and the sample surface depends on parameters such as the intensity and frequency of the RF power used to excite the plasma, the type of gas(es) that are ionized, the pressure and flow rate of the gas(es), the sample surface material, and the duration of the plasma process.

## ABOUT THE VACUUM PUMP

### VACUUM PUMP REQUIREMENTS

Our plasma cleaners require these pump specifications:

- Pump must be compatible with the gas(es) used
- Minimum pumping speed of 1.4 m<sup>3</sup>/h (23 L/min)
- Ultimate total pressure of  $\leq 200$  mTorr (0.27 mbar)

If using your own vacuum pump, you must also provide accessories to connect the plasma chamber to the pump inlet. *Figure 1* shows example vacuum pumps and accessories.

- The plasma chamber narrows down to a 1/2" outer diameter (OD) tube in the back. Use a 3 feet (1 meter) length of vacuum-rated 1/2" inner diameter (ID) flexible hose.
- Use hose clamps on either ends of the vacuum hose to seal the connection.
- Use 1/2" OD hose adaptor and appropriate swing clamp and centering ring to connect the vacuum hose to the pump inlet.
- We recommend attaching an exhaust hose to your pump outlet to conduct the pump exhaust away from the lab space and to a fume hood.

### GUIDELINES FOR SETTING UP THE VACUUM PUMP

#### **VACUUM GREASE**

*Do NOT use vacuum grease on any of the vacuum connections of the plasma cleaner, vacuum pump, or accessories as it can be a source of contamination. Sufficient vacuum pressure can be achieved without using vacuum grease. If you observe insufficient vacuum pressure level, this suggests a vacuum leak in your plasma system or a vacuum pump problem. Contact Harrick Plasma for further assistance.*

#### **MATERIALS COMPABILITY**

*The material of the vacuum hose and connection accessories must be compatible with the gas(es) used.*

#### **VACUUM HOSE LENGTH**

*Keep the vacuum hose length as short as possible to minimize the time required to evacuate the chamber. We recommend using a vacuum hose length of 3 feet (1 meter).*

## ABOUT THE VACUUM PUMP

### (A) • PDC-OPD Dry Oxygen Service Pump

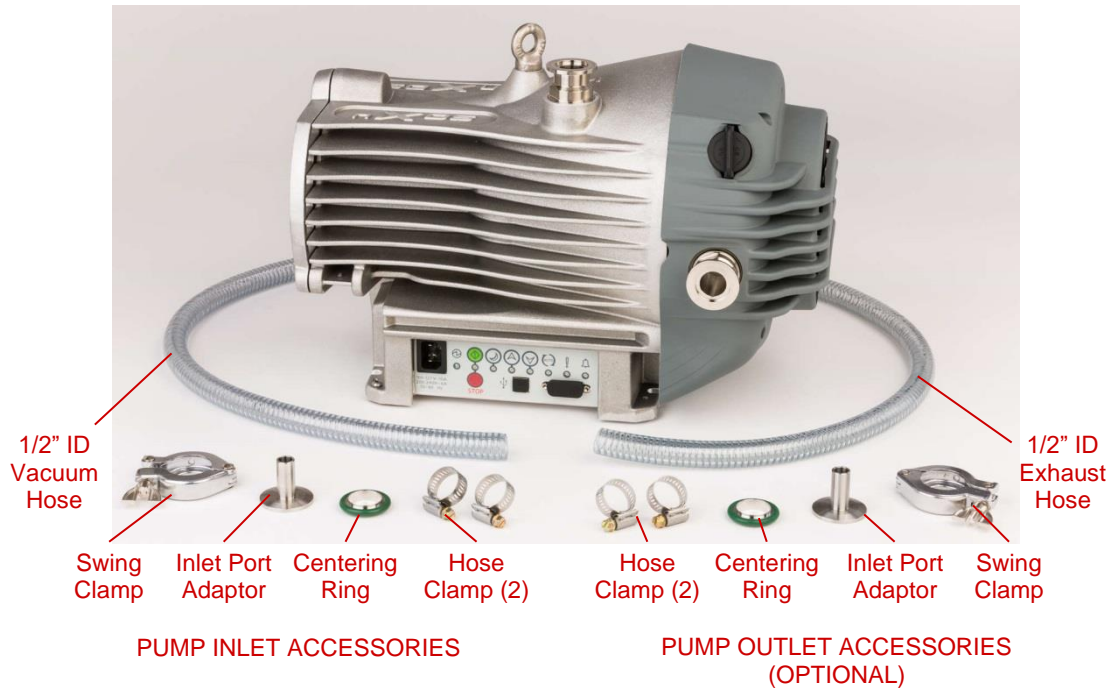

### (B) • PDC-OPE Economy Dry Oxygen Service Pump

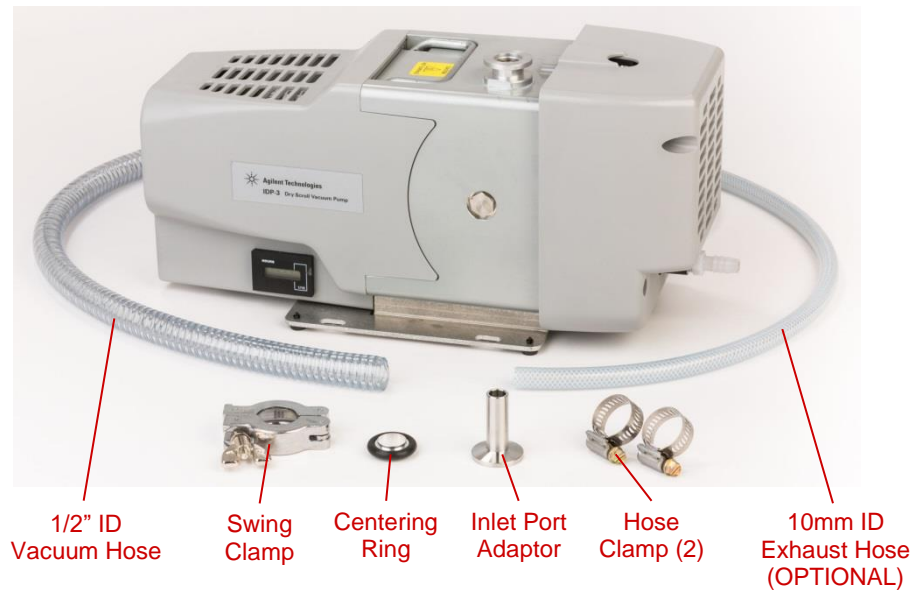

**FIGURE 1 • Example Vacuum Pumps and Accessories**

## ABOUT THE VACUUM PUMP

### SETTING UP THE VACUUM PUMP

Figure 2 shows a dry pump as an example to demonstrate setup. If you purchased a vacuum pump from Harrick Plasma, refer to your vacuum pump packing checklist for installation instructions specific to your purchased pump.

If providing your own vacuum pump, see previous section, *VACUUM PUMP REQUIREMENTS*, to ensure that your pump is suitable for use with the Plasma Cleaner. The instructions below serve as a guide to configure your pump with the Plasma Cleaner. Also consult with your pump supplier for appropriate accessories to connect the plasma chamber to the pump inlet.

To set up the pump for use with the Plasma Cleaner:

- If applicable, fill the vacuum pump with the appropriate pump oil or fluid. Refer to the pump manual for instructions and oil/fluid capacity. Note that Fomblin-prepared pumps for oxygen service require Fomblin fluid, not pump oil.
- Place the centering ring on top of the vacuum pump inlet (*Figure 2A*).
- Place the inlet port adaptor on top of the centering ring (*Figure 2B*).
- Wrap the swing clamp around the inlet port adaptor and centering ring. Tighten the swing clamp using the wing nut (*Figure 2C*).
- Connect the 1/2" ID vacuum hose to the inlet port adaptor on the pump. Tighten a hose clamp over the end of the hose (*Figure 2D*).
- We recommend that the pump exhaust from the pump outlet be properly vented, either by conducting the pump exhaust to a fume hood through an exhaust hose or attaching an oil mist filter to the pump outlet. If you purchased a vacuum pump from Harrick Plasma, pump outlet accessories can be provided.



**CAUTION:**

*For processing with pure oxygen, make sure to use an oxygen compatible vacuum pump. Vacuum pumps that use hydrocarbon pump oil are NOT oxygen compatible. Contact Harrick Plasma about available oxygen service pumps.*

*For reactive or corrosive gases, ensure that the seals, tubing, and vacuum connection materials of the Plasma Cleaner and vacuum pump are chemically compatible with the gases. Use a suitable vacuum pump for corrosive gases. Contact Harrick Plasma to determine materials compatibility and appropriate materials substitutions for your gases.*

## ***ABOUT THE VACUUM PUMP***

**(A) • Centering ring on pump inlet**



**(B) • Inlet port adaptor on centering ring**



**(C) • Swing clamp around inlet port adaptor**



**(D) • Attach vacuum hose**



**FIGURE 2 • Setting Up an Example Vacuum Pump**

## ABOUT THE PLASMA CLEANER

### PARTS OF THE PLASMA CLEANER

Figure 3 identifies parts of the Plasma Cleaner (115V).

(A) • Front view

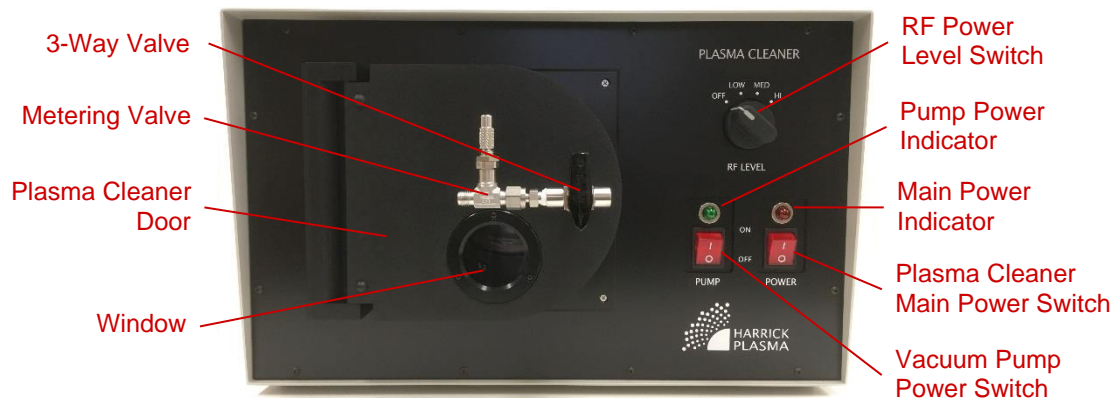

(B) • Back view

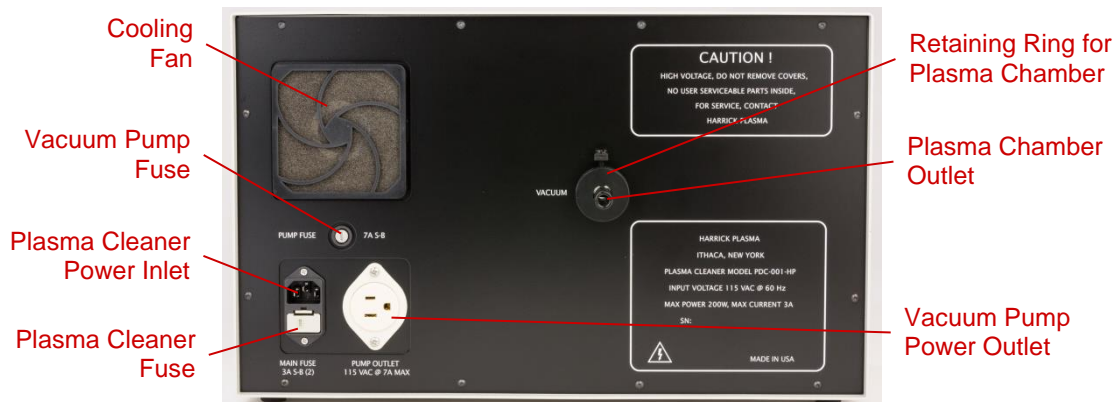

Figure 3 • PDC-001-HP High Power Expanded Plasma Cleaner (115V)

**NOTE:** The PDC-001-HP is rated for 115V at 60Hz but can accept line voltages of 110-120V at 50-60Hz.



## ABOUT THE PLASMA CLEANER

### PARTS OF THE PLASMA CLEANER

Figure 4 identifies parts of the Plasma Cleaner (230V).

(A) • Front view

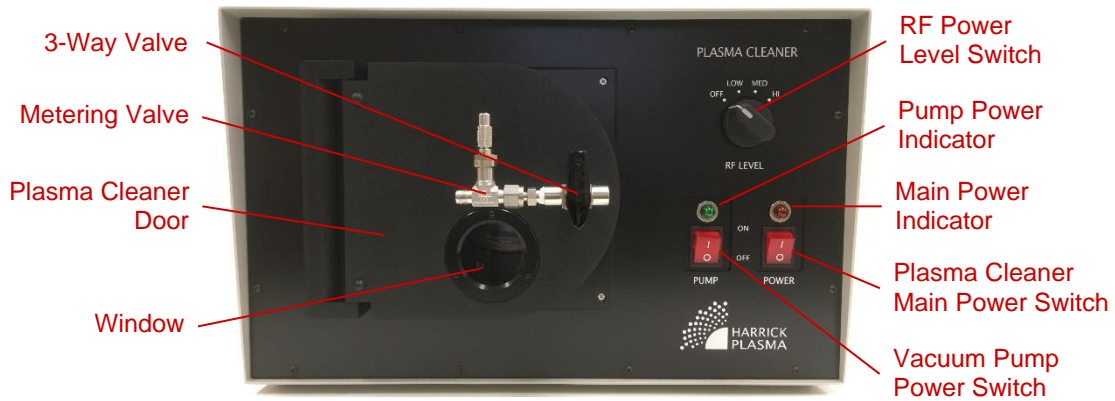

(B) • Back view

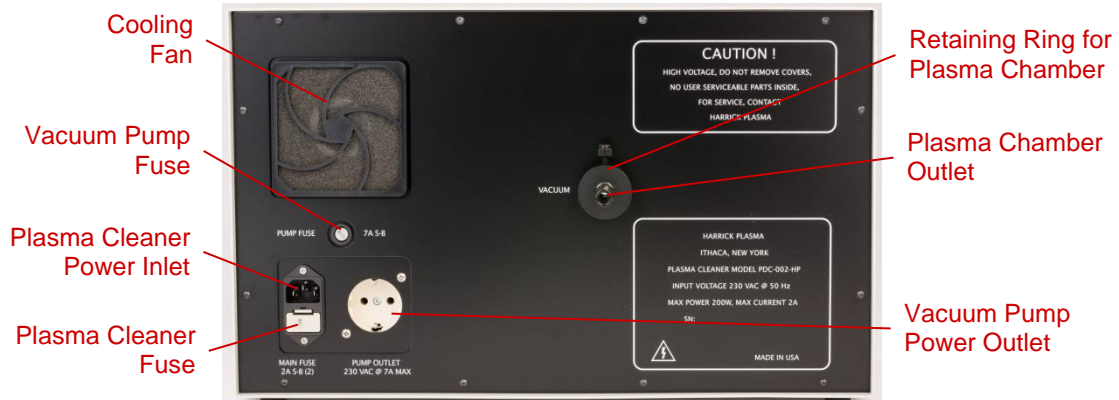

Figure 4 • PDC-002-HP High Power Expanded Plasma Cleaner (230V)

**NOTE:** The PDC-002-HP is rated for 230V at 50Hz but can accept line voltages of 220-240V at 50-60Hz.

## ABOUT THE PLASMA CLEANER

### SETTING UP THE PLASMA CLEANER

Before proceeding, see previous section, *ABOUT THE VACUUM PUMP*, on how to set up the vacuum pump for use with the Plasma Cleaner.

To set up the Plasma Cleaner:

- Connect the metering valve/3-way valve to the Plasma Cleaner door (*Figure 5*).
- Connect the plasma chamber outlet at the back of the Plasma Cleaner (*Figure 6*) to the vacuum pump using 1/2" ID vacuum hose. Tighten hose clamps over the hose at each end.
- Plug in the Plasma Cleaner power cord.

To control the vacuum pump power, use one of the options described below. These options are a matter of convenience and do not affect the plasma cleaner performance.

- To control the vacuum pump power from the Plasma Cleaner front panel (*Figure 3A* or *Figure 4A*), plug the vacuum pump power cord into the vacuum pump power outlet at the back of the Plasma Cleaner (*Figure 3B* or *Figure 4B*). Set the vacuum pump's power switch to ON and leave it on. The pump power may now be directly controlled by the pump power switch on the Plasma Cleaner front panel.
- To control the vacuum pump power independent of the Plasma Cleaner, plug the vacuum pump power directly into an electrical outlet and use the power switch located on the pump.

#### **NPT CONNECTIONS**

*When connecting NPT tapered threads, always wrap the thread with PTFE (Teflon) tape to ensure a good seal. Remove any debris or residual tape on the internal and external threads before wrapping with new tape and reconnecting. Wrap the tape in the direction counter to the screw direction. TIGHTEN ALL THREADED CONNECTIONS WITH A WRENCH.*

#### **SWAGELOK CONNECTIONS**

*Swagelok fittings use a set of nut and ferrule to seal the connection and do NOT require Teflon tape on the threads (see *Figure 13B* as an example).*



#### **CAUTION:**

*The vacuum pump electrical outlet at the back of the Plasma Cleaner is designed for vacuum pumps requiring up to 7 Amps. **DO NOT** plug a vacuum pump whose input electrical current requirement exceeds 7 Amps into the Plasma Cleaner's vacuum pump outlet. Rather, plug the pump directly into an electrical outlet.*

## ABOUT THE PLASMA CLEANER



Figure 5 • Connecting the Metering Valve/3-Way Valve to the Plasma Cleaner Door



Figure 6 • Connecting the Vacuum Hose to the Plasma Chamber Outlet

## ABOUT THE OPTIONAL PDC-VCG / PDC-VCG-2 VACUUM GAUGE AND DIGITAL METER

### PARTS OF THE VACUUM GAUGE AND DIGITAL METER

Figure 7 identifies parts of the Vacuum Gauge and Digital Meter (115V).

(A) • Front view

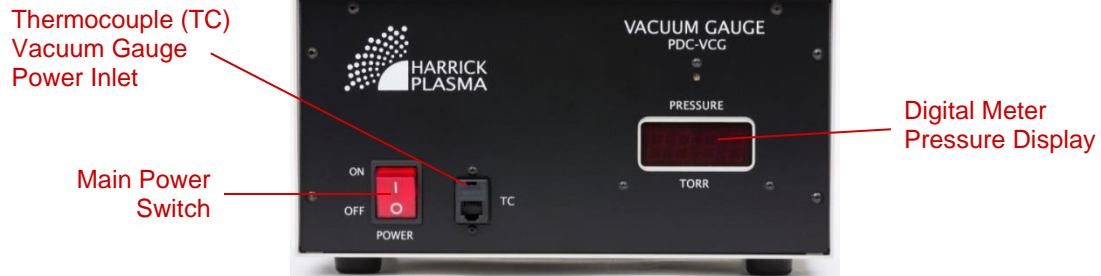

(B) • Back view



(C) • Vacuum Gauge and Accessory



FIGURE 7 • PDC-VCG Vacuum Gauge and Digital Meter (115V)

**NOTE:** The PDC-VCG is rated for 115V at 60Hz but can accept line voltages of 110-120V at 50-60Hz.

# ABOUT THE OPTIONAL PDC-VCG / PDC-VCG-2 VACUUM GAUGE AND DIGITAL METER

## PARTS OF THE VACUUM GAUGE AND DIGITAL METER

Figure 8 identifies parts of the Vacuum Gauge and Digital Meter (230V).

(A) • Front view

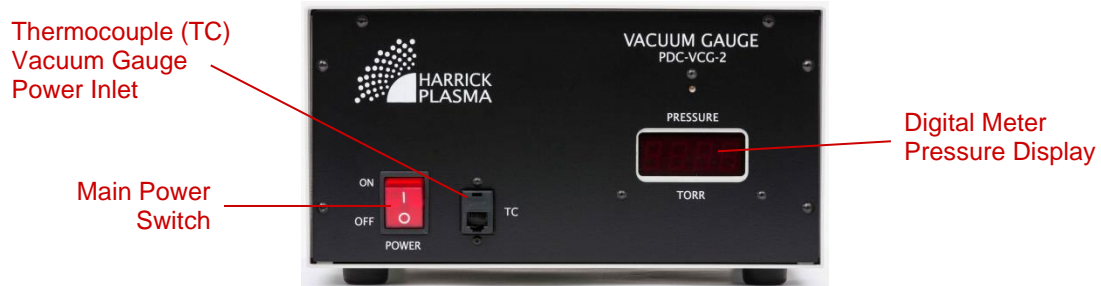

(B) • Back view



(C) • Vacuum Gauge and Accessory



FIGURE 8 • PDC-VCG-2 Vacuum Gauge and Digital Meter (230V)

**NOTE:** The PDC-VCG-2 is rated for 230V at 50Hz but can accept line voltages of 220-240V at 50-60Hz.



## **ABOUT THE OPTIONAL PDC-VCG / PDC-VCG-2 VACUUM GAUGE AND DIGITAL METER**

### **SETTING UP THE VACUUM GAUGE AND DIGITAL METER**

Before proceeding, see previous sections, *ABOUT THE VACUUM PUMP* and *ABOUT THE PLASMA CLEANER*, on how to set up the vacuum pump and Plasma Cleaner.

To set up Vacuum Gauge and Digital Meter:

- Connect the metering valve/3-way valve assembly to the thermocouple (TC) vacuum gauge assembly. Tighten with a wrench. If the PDC-VCG / VCG-2 and Plasma Cleaner were purchased together, the metering valve/3-way valve/TC vacuum gauge assembly would be pre-assembled (*Figure 9*).
- If using a gas cylinder source and using the Swagelok hose adaptor supplied with the PDC-VCG / VCG-2 (*Figure 7C* or *Figure 8C*), connect the Swagelok hose adaptor to the metering valve input (tighten with a wrench). The Swagelok hose adaptor is shown connected to the metering valve input in *Figure 9*. The Swagelok hose adaptor accepts 1/4" ID flexible tubing. Seal both ends of the gas tubing with hose clamps. See *Figure 13A* as an example.
- If using a gas cylinder source and other types of tubing and adaptors, note the metering valve has 1/4" Swagelok fittings, which can be fitted with 1/4" Swagelok nut and ferrule set and 1/4" OD rigid tubing. *Figure 13B* shows an example.
- Connect the metering valve/3-way valve/TC vacuum gauge assembly to the Plasma Cleaner door. Tighten with a wrench. The TC vacuum gauge should be vertical with electrical pins pointing up (*Figure 9*).
- Connect the vacuum gauge cable between the TC vacuum gauge and the thermocouple vacuum gauge inlet (TC) on the PDC-VCG / VCG-2 front panel (see *Figure 7C* or *Figure 8C*).
- Plug in the PDC-VCG / VCG-2 power cord.

#### **NPT CONNECTIONS**

*When connecting NPT tapered threads, always wrap the thread with PTFE (Teflon) tape to ensure a good seal. Remove any debris or residual tape on the internal and external threads before wrapping with new tape and reconnecting. Wrap the tape in the direction counter to the screw direction. TIGHTEN ALL THREADED CONNECTIONS WITH A WRENCH.*

#### **SWAGELOK CONNECTIONS**

*Swagelok fittings use a set of nut and ferrule to seal the connection and do NOT require Teflon tape on the threads (see *Figure 13B* as an example).*

## ABOUT THE OPTIONAL PDC-VCG / PDC-VCG-2 VACUUM GAUGE AND DIGITAL METER

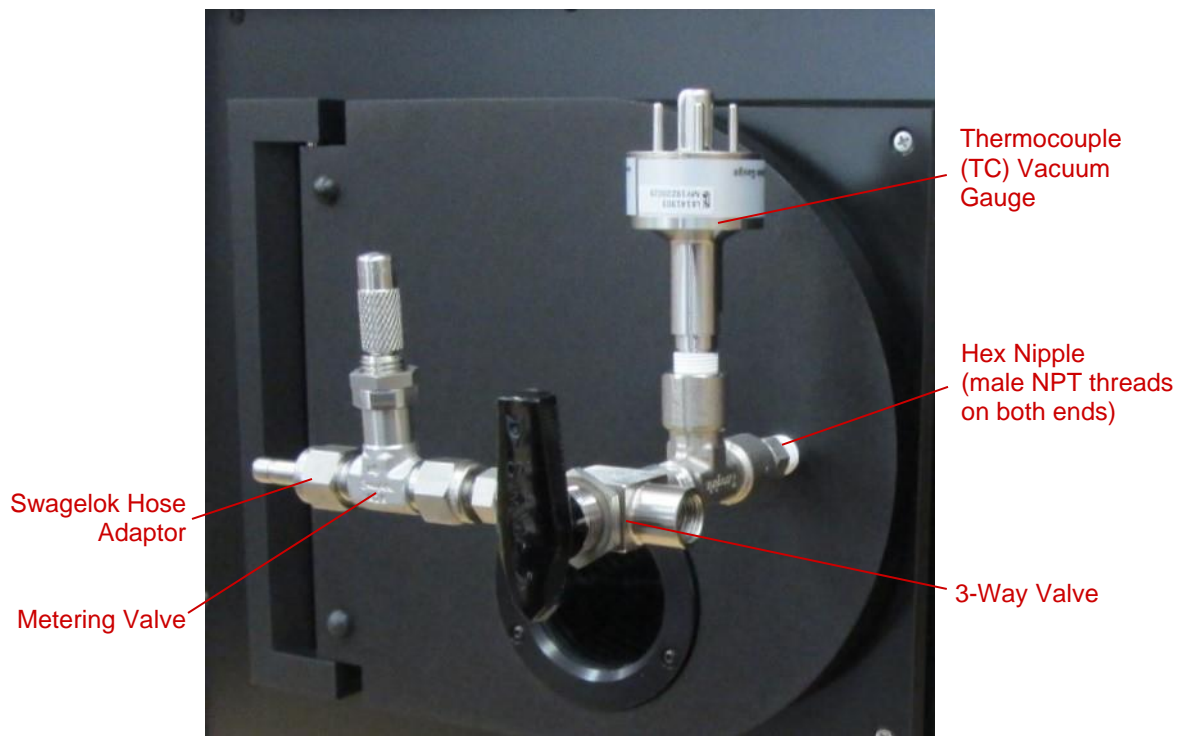

**FIGURE 9 • Final Configuration of the Metering Valve, 3-Way Valve, and TC Vacuum Gauge on the Plasma Cleaner Door When Using the Optional PDC-VCG / PDC-VCG-2 or PDC-FMG / PDC-FMG-2 PlasmaFlo**

(The vacuum gauge should be oriented vertically with electrical pins pointing up, as shown above)

## ABOUT THE OPTIONAL PDC-FMG / PDC-FMG-2 PLASMAFLO

### PARTS OF THE PLASMAFLO

Figure 10 and Figure 12 identify parts of the PlasmaFlo (115V).

#### (A) • Front view

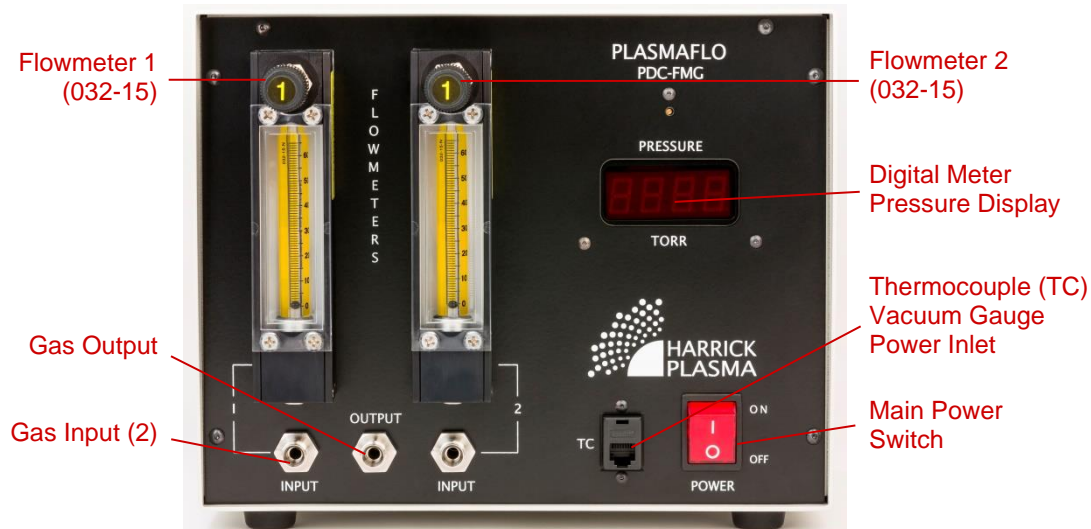

#### (B) • Back view



FIGURE 10 • PDC-FMG PlasmaFlo (115V)

**NOTE:** The PDC-FMG is rated for 115V at 60Hz but can accept line voltages of 110-120V at 50-60Hz.



## ABOUT THE OPTIONAL PDC-FMG / PDC-FMG-2 PLASMAFLO

### PARTS OF THE PLASMAFLO

Figure 11 and Figure 12 identify parts of the PlasmaFlo (230V).

#### (A) • Front view

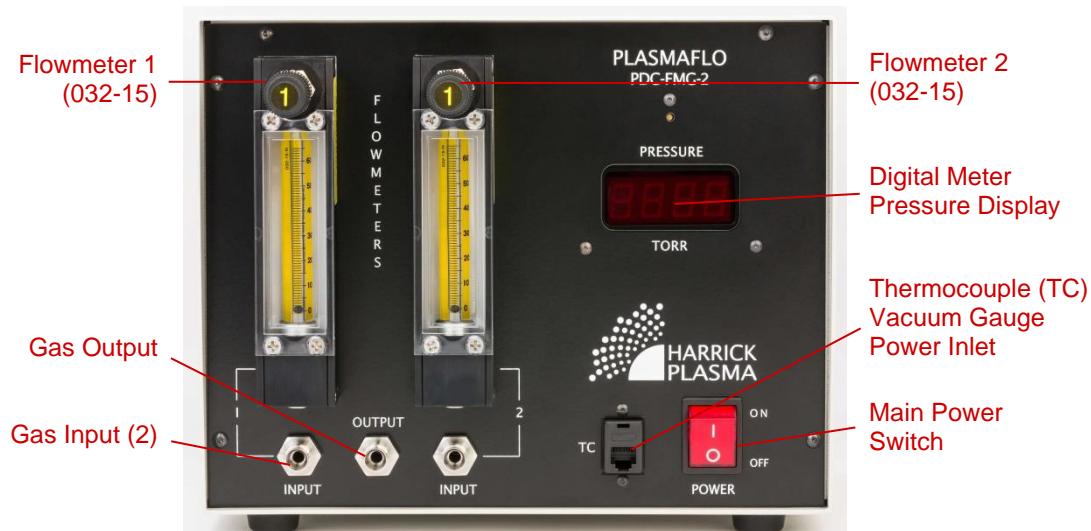

#### (B) • Back view



FIGURE 11 • PDC-FMG-2 PlasmaFlo (230V)

**NOTE:** The PDC-FMG-2 is rated for 230V at 50Hz but can accept line voltages of 220-240V at 50-60Hz.

## ABOUT THE OPTIONAL PDC-FMG / PDC-FMG-2 PLASMAFLO

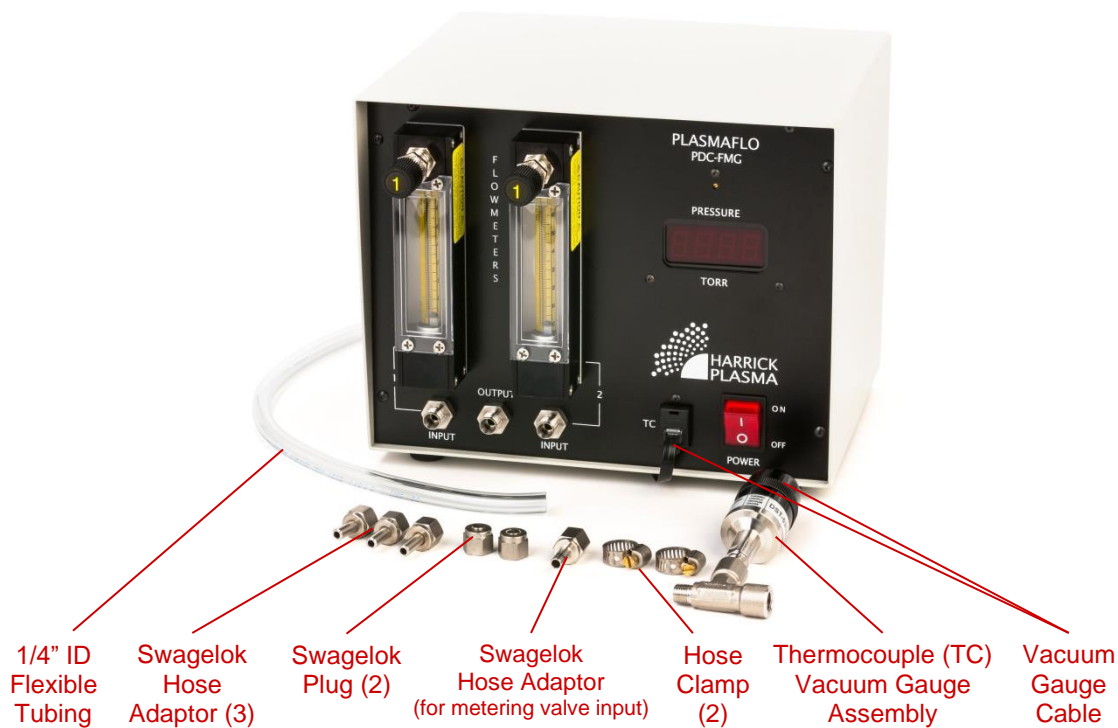

**FIGURE 12 • PlasmaFlo and Accessories**

**(A) Using supplied Swagelok hose adaptors and 1/4" ID flexible tubing**

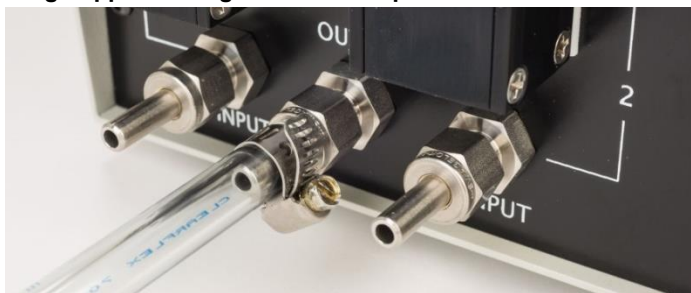

**(B) Using 1/4" Swagelok nut/ferrule set and 1/4" OD rigid tubing**



**FIGURE 13 • Setting Up PlasmaFlo Gas Output and Input(s)**

## ABOUT THE OPTIONAL PDC-FMG / PDC-FMG-2 PLASMAFLO

### SETTING UP THE PLASMAFLO

Before proceeding, see previous sections, *ABOUT THE VACUUM PUMP* and *ABOUT THE PLASMA CLEANER*, on how to set up the vacuum pump and Plasma Cleaner.

To set up the PlasmaFlo:

- Connect the metering valve/3-way valve assembly to the thermocouple (TC) vacuum gauge assembly. Tighten with a wrench. If the PlasmaFlo and Plasma Cleaner were purchased together, the metering valve/3-way valve/TC vacuum gauge assembly would be pre-assembled (*Figure 9*).
- Connect the metering valve/3-way valve/TC vacuum gauge assembly to the Plasma Cleaner door. Tighten with a wrench. The TC vacuum gauge should be vertical with electrical pins pointing up (*Figure 9*).
- Connect the vacuum gauge cable between the TC vacuum gauge and the thermocouple vacuum gauge inlet (TC) on the PlasmaFlo front panel (*Figure 12*).
- Plug in the PlasmaFlo power cord.

To connect gas tubing between the PlasmaFlo gas output and the metering valve input on the Plasma Cleaner door, use one of the options described below.

- If using the Swagelok hose adaptors and 1/4" ID flexible tubing supplied with the PlasmaFlo (*Figure 12*), connect the Swagelok hose adaptor to the PlasmaFlo gas output (tighten with a wrench). Connect the Swagelok hose adaptor to the metering valve input (tighten with a wrench). The Swagelok hose adaptor is shown connected to the metering valve input in *Figure 9*. Connect the flexible tubing between the PlasmaFlo gas output and the metering valve input. Tighten hose clamps over each end of the flexible tubing. See *Figure 13A* as an example.
- If using other types of tubing and adaptors, note the metering valve and PlasmaFlo gas output have 1/4" Swagelok fittings, which can be fitted with 1/4" Swagelok nut and ferrule set and 1/4" OD rigid tubing. *Figure 13B* shows an example.

#### SWAGELOK CONNECTIONS

*Swagelok fittings use a set of nut and ferrule to seal the connection and do NOT require Teflon tape on the threads (see *Figure 13B* as an example).*



#### **CAUTION:**

*For reactive or corrosive gases, ensure that the seals, tubing, and vacuum connection materials of the entire plasma system are chemically compatible with the gases. Use a suitable vacuum pump for corrosive gases. Contact Harrick Plasma to determine materials compatibility and appropriate materials substitutions for your gases.*

### GUIDELINES FOR SETTING UP THE GAS CYLINDER

If using ambient air, skip to the next section,  
*PLASMA PROCESSING*.

If using process gas from a gas cylinder, see the  
guidelines and instructions below.

#### **PRESSURE REGULATOR SELECTION**

*Use a pressure regulator that is compatible with the  
process gas and that has the same connection size as on  
the gas cylinder. For added safety, include an isolation  
valve at the regulator output.*

*A two-stage regulator is able to provide more stable  
regulated pressures under conditions where downstream  
pressures (at the plasma chamber) may fluctuate and is  
recommended over a single-stage regulator.*

*For gas input directly to the plasma cleaner, we  
recommend using regulated pressures of 5-10 psig.*

*For gas input to the optional PlasmaFlo, we recommend  
using regulated pressures of 10 psig to enable use of the  
correlated flowrate tables provided for the flowmeters in  
APPENDIX A. Inquire with Harrick Plasma if other  
regulated pressures are desired.*

#### **PURGE GAS LINE(S) PRIOR TO INSTALLATION**

*All gas lines should be purged of any dust or residual  
contamination prior to installation.*

*On the optional PlasmaFlo, to prevent the float from  
potentially getting stuck along the flowtube of the  
flowmeter(s), use only dry, clean gas.*

#### **NPT CONNECTIONS**

*When connecting NPT tapered threads, always wrap the  
thread with PTFE (Teflon) tape to ensure a good seal.  
Remove any debris or residual tape on the internal and  
external threads before wrapping with new tape and  
reconnecting. Wrap the tape in the direction counter to  
the screw direction. **TIGHTEN ALL THREADED  
CONNECTIONS WITH A WRENCH.***

#### **SWAGELOK CONNECTIONS**

*Swagelok fittings use a set of nut and ferrule to seal the  
connection and do NOT require Teflon tape on the  
threads (see Figure 13B as an example).*



#### **CAUTION:**

*For reactive or corrosive gases, ensure that the seals, tubing, and vacuum connection materials of the entire plasma system are chemically compatible with the gases. Use a suitable vacuum pump for corrosive gases. Contact Harrick Plasma to determine materials compatibility and appropriate materials substitutions for your gases.*

**CONNECTING THE GAS  
DIRECTLY TO THE PLASMA  
CLEANER**

Before proceeding, see previous sections, *ABOUT THE VACUUM PUMP* and *ABOUT THE PLASMA CLEANER*, on how to set up the vacuum pump and Plasma Cleaner.

If using the optional PDC-VCG / PDC-VCG-2, also see previous section, *ABOUT THE OPTIONAL PDC-VCG / PDC-VCG-2 VACUUM GAUGE AND DIGITAL METER*.

To connect the gas line to the Plasma Cleaner:

- Attach an appropriate pressure regulator to the gas cylinder. See previous section, *GUIDELINES FOR SETTING UP THE GAS CYLINDER: PRESSURE REGULATOR SELECTION*.
- If using the optional PDC-VCG / VCG-2, connect the Swagelok hose adaptor to the metering valve input (tighten with a wrench). The Swagelok hose adaptor is shown connected to the metering valve input in *Figure 9*. Use appropriate hose adaptors at the gas cylinder pressure regulator output and 1/4" ID flexible tubing to connect the regulator output to the metering valve input. Tighten hose clamps over each end of the tubing. See *Figure 13A* as an example.
- Otherwise, note the metering valve has 1/4" Swagelok fittings, which can be fitted with 1/4" Swagelok nut and ferrule set and 1/4" OD rigid tubing (see *Figure 13B* as an example).
- Ensure that the tubing and adaptor materials are chemically compatible with the gases.

**SWAGELOK CONNECTIONS** *Swagelok fittings use a set of nut and ferrule to seal the connection and do NOT require Teflon tape on the threads (see Figure 13B as an example).*

### CONNECTING THE GAS TO THE PLASMAFLO

Before proceeding, see previous sections, *ABOUT THE VACUUM PUMP*, *ABOUT THE PLASMA CLEANER*, and *ABOUT THE OPTIONAL PDC-FMG / PDC-FMG-2 PLASMAFLO*, on how to set up the vacuum pump, Plasma Cleaner, and PlasmaFlo.

To connect the gas line to the PlasmaFlo gas inputs:

- Attach an appropriate pressure regulator to the gas cylinder. See previous section, *GUIDELINES FOR SETTING UP THE GAS CYLINDER: PRESSURE REGULATOR SELECTION*.
- If using the Swagelok hose adaptors supplied with the PlasmaFlo (see *Figure 12*), connect the Swagelok hose adaptor to the PlasmaFlo gas inputs (tighten with a wrench). Use appropriate hose adaptors at the pressure regulator output and 1/4" ID flexible tubing to connect the regulator output to the PlasmaFlo gas inputs. Tighten hose clamps over each end of the tubing. See *Figure 13A* as an example.
- If using other types of tubing and adaptors, note the metering valve and PlasmaFlo gas inputs have 1/4" Swagelok fittings, which can be fitted with 1/4" Swagelok nut and ferrule set and 1/4" OD rigid tubing (see *Figure 13B* as an example).
- Ensure that the tubing and adaptor materials are chemically compatible with the gases.

### SWAGELOK CONNECTIONS

*Swagelok fittings use a set of nut and ferrule to seal the connection and do NOT require Teflon tape on the threads (see *Figure 13B* as an example).*

### USING ONE GAS WITH THE PLASMAFLO

*If you are only using one gas input, use the Swagelok stainless steel plug (included with the PlasmaFlo) to seal the unused gas input (*Figure 14*).*



**FIGURE 14 • Using the PlasmaFlo with One Gas Source**

(Seal unused gas input with supplied Swagelok plug)



This page intentionally left blank.

**(A) • To input ambient air or gas**

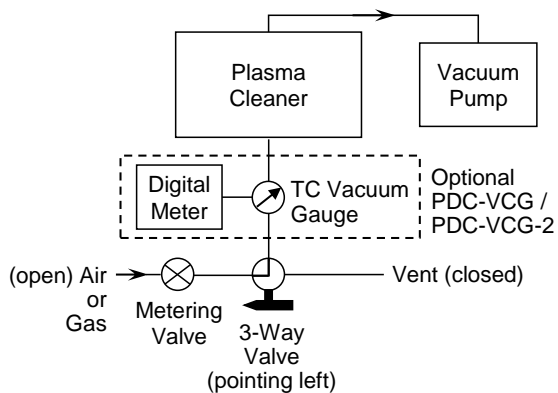

**(B) • To vent**

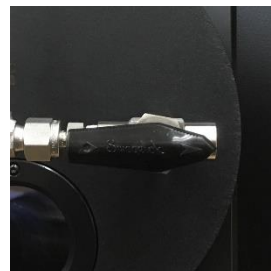
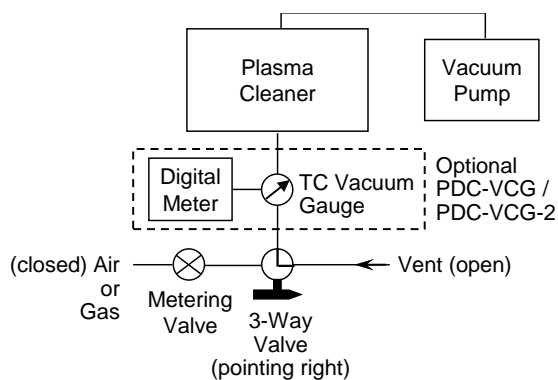

**(C) • 3-way valve closed (plasma chamber isolated)**

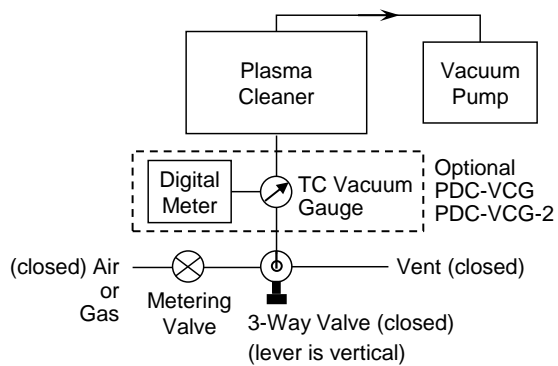

**FIGURE 15 • Processing with Air or Gas Connected Directly to the Plasma Cleaner**



### GUIDELINES FOR PLASMA PROCESSING

#### **USING THE METERING VALVE**

**DO NOT APPLY EXCESSIVE FORCE WHEN CLOSING THE METERING VALVE.**

*The metering valve is meant only for fine control of the gas flow into the chamber and is not intended to be a shut-off valve. Instead, use the 3-way valve as a shut-off valve to isolate the chamber (Figure 15C or Figure 17C).*

*If using the PlasmaFlo, use of the metering valve is optional as the flowmeters will provide fine control of the gas flowrate. The metering valve can be kept as part of the plasma system and left open. Alternatively, the metering valve can be removed and the PlasmaFlo gas output tubing can be connected directly to the 3-way valve on the Plasma Cleaner.*

#### **USING THE 3-WAY VALVE**

*If the same plasma process will be used repeatedly with no change to the process conditions, the metering valve can be fixed to the desired setting. Instead, use the 3-way valve to switch between inputting gas, venting, and isolating the chamber (Figure 15 or Figure 17).*

#### **USING THE FLOWMETERS ON THE OPTIONAL PLASMAFLO**

*Flowmeters with a 65mm reference scale are provided to enable use with a broad range of gases.*

*Correlated flowrate tables that convert the millimeter (mm) scale reading to a flowrate (mL/min) are available for the most common gases used with the Plasma Cleaner, metered at 10 psig (see APPENDIX A).*

*Flowrate tables for other gases or regulated pressures can be made available. Inquire with Harrick Plasma.*

**DO NOT APPLY EXCESSIVE FORCE WHEN CLOSING THE FLOWMETER VALVES.**

*The flowmeter valves are meant only for fine control of the gas flow rate and are not intended to be shut-off valves. Instead, install a shut-off valve at the gas cylinder pressure regulator output or use the 3-way valve to isolate the chamber (Figure 15C or Figure 17C).*

#### **PROCESS CONDITIONS**

*By selecting the process gases, pressure, RF power, and plasma treatment time, the nature and extent of the surface interactions can be tailored for your application.*

*For cleaning, 500-900 mTorr pressure, HIGH RF power, and 1-3 minutes are good initial process conditions. The timing of the plasma treatment should begin when a plasma glow is first observed. Note: this is a general guide as a wide range of process conditions have been reported for cleaning. Some experimentation may be required to determine the optimal process conditions for your specific sample material and application.*

**CAUTION:**

*After completing the plasma process, the Plasma Cleaner main power should be turned off to prevent overheating and possible damage to the Plasma Cleaner.*

*If you are working with toxic or reactive gases, the gases must be handled with extreme caution. To avoid releasing these gases into the ambient environment, we recommend running several purge cycles after plasma processing (flood the chamber with inert gas and allow it to pump out) to ensure the gases are properly evacuated from the gas line and chamber prior to venting. The pump exhaust must also be properly vented.*

*See PURGING REACTIVE GASES FROM THE PLASMA CLEANER for general guidelines on how to set up the Plasma Cleaner to purge with inert gas. Also contact your gas supplier for safe gas handling procedures specific to your process gas.*

**PROCESSING WITH AIR OR  
GAS CONNECTED  
DIRECTLY TO THE  
PLASMA CLEANER****EVACUATING THE CHAMBER**

- Turn on the Plasma Cleaner main power.
- Put the sample in the chamber.
- Check that the 3-way valve is closed (lever is vertical, *Figure 15C*).
- Close and hold the door against the chamber.
- Turn on the vacuum pump. The vacuum will hold the door in place. Evacuate the chamber for 1-3 minutes or to the desired vacuum pressure. If using a gas cylinder source, we recommend evacuating the chamber to <100 mTorr to remove as much residual air as possible before introducing the process gas. Depending on the pump specifications and assuming no significant vacuum leaks, it may require 20-30 minutes to reach <100 mTorr pressure.

**INPUTTING GAS**

- If using gas from a gas cylinder, open the gas cylinder valve (and isolation valve at regulator output) and adjust the regulator pressure to 5-10 psig.
- Open the 3-way valve to air or gas (lever points to the metering valve, *Figure 15A*).
- Slightly open the metering valve (by 1/8 of a turn or less) and allow the gas to flow for 30-60 seconds. If using the optional PDC-VCG / PDC-VCG-2 vacuum gauge and digital meter, adjust the metering valve to the desired vacuum pressure and allow the pressure to stabilize.

### GENERATING PLASMA

- Select the desired RF power level.
- Look through the viewing window for the plasma glow and indication that plasma has formed (*Figure 16* shows an example of an air plasma).
- If needed, adjust the metering valve slightly until the plasma intensity is visibly maximized. This broadly corresponds to optimal plasma generation conditions.

### PLASMA TREATMENT

- Process the sample for the desired duration. The timing of the plasma treatment should begin when the plasma glow is first observed.
- At the end of the process, turn off the RF power.
- If using a gas cylinder source, close the gas cylinder valve (and isolation valve at regulator output).
- Allow 1-3 minutes for the vacuum pump to evacuate any residual process gas from the chamber.
- Close the 3-way valve (lever is vertical, *Figure 15C*).
- If using toxic or reactive gases, see section, *PURGING REACTIVE GASES FROM THE PLASMA CLEANER* for guidelines on purging the Plasma Cleaner with inert gas following plasma treatment.

### VENTING THE CHAMBER

- Turn off the vacuum pump.
- Slowly open the 3-way valve to vent (lever points to vent, *Figure 15B*).
- Once atmospheric pressure is reached, close the 3-way valve (lever is vertical, *Figure 15C*).
- Turn off the Plasma Cleaner main power.
- Open the door and remove the sample.



**FIGURE 16 • Example of an Air Plasma**

(The plasma color and intensity can vary with the gas and process conditions used)



**CAUTION:**

To prevent liquid oil backstreaming when using an oil-based vacuum pump, we recommend venting immediately after plasma processing and using a vacuum pump with an inlet check valve, such as those offered by Harrick Plasma.

**(A) • To process gas**

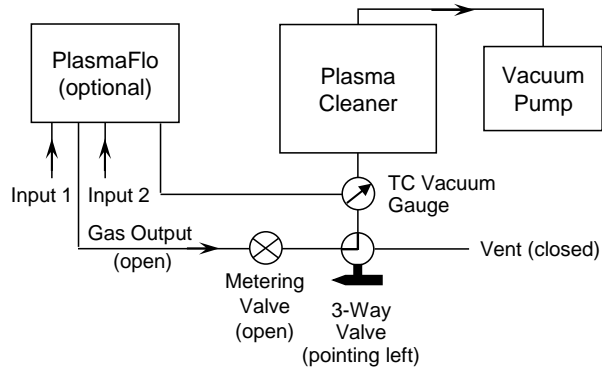

**(B) • To vent**

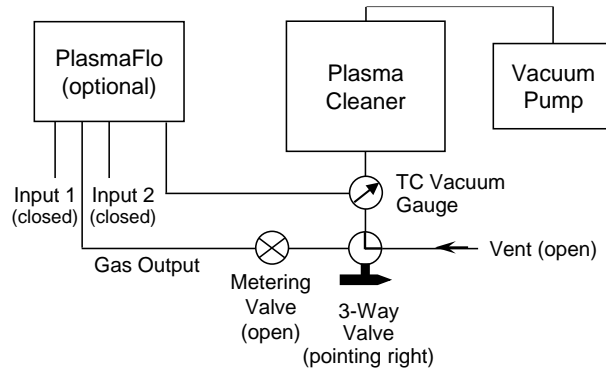

**(C) • 3-way valve closed  
(plasma chamber isolated)**

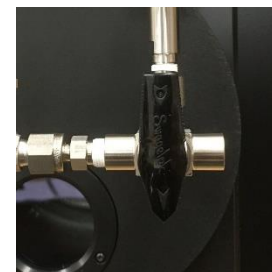
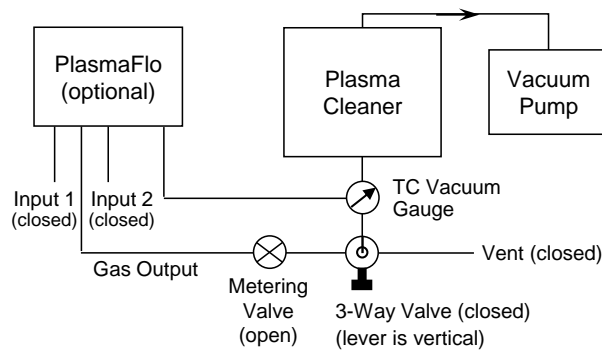

**FIGURE 17 • Processing with Gas Connected to the PlasmaFlo**



This page intentionally left blank.

**CAUTION:**

*After completing the plasma process, the Plasma Cleaner main power should be turned off to prevent overheating and possible damage to the Plasma Cleaner.*

*If you are working with toxic or reactive gases, the gases must be handled with extreme caution. To avoid releasing these gases into the ambient environment, we recommend running several purge cycles after plasma processing (flood the chamber with inert gas and allow it to pump out) to ensure the gases are properly evacuated from the gas line and chamber prior to venting. The pump exhaust must also be properly vented.*

*See PURGING REACTIVE GASES FROM THE PLASMA CLEANER for general guidelines to set up the Plasma Cleaner to purge with inert gas. Also contact your gas supplier for safe gas handling procedures specific to your process gas.*

**PROCESSING WITH GAS  
USING THE PLASMAFLO****EVACUATING THE CHAMBER**

- Turn on the PlasmaFlo main power.
- Turn on the Plasma Cleaner main power.
- Put the sample in the chamber.
- Check that the 3-way valve is closed (lever is vertical, *Figure 17C*).
- Close and hold the door against the chamber.
- Turn on the vacuum pump. The vacuum will hold the door in place. Evacuate the chamber for 1-3 minutes or to the desired vacuum pressure. If using a gas cylinder source, we recommend evacuating the chamber to <100 mTorr to remove as much residual air as possible before introducing the process gas. Depending on the pump specifications and assuming no significant vacuum leaks, it may require 20-30 minutes to reach <100 mTorr pressure.

**INPUTTING GAS**

- If the metering valve is part of the plasma system, leave the metering valve open (see *GUIDELINES FOR PLASMA PROCESSING*).
- Open the 3-way valve to process gas (lever points to the metering valve, *Figure 17A*). The vacuum pressure will initially increase but will gradually decrease again as the residual air in the gas line is evacuated.
- Open the process gas cylinder valve(s) and adjust the regulator pressure to 10 psig. Slowly open the regulator isolation valve. The floats in the flowmeter flowtube may rise slightly due to the sudden pressure increase upon opening the regulator isolation valve.

### INPUTTING GAS (continued)

- Slowly open the flowmeter valve(s) and set the desired flowrate or set the flow level to obtain the desired pressure. Read off the millimeter (mm) reference scale reading, along the flowtube, from the center of the float. See *APPENDIX A* to convert the mm scale reading to a flowrate (mL/min). The float position may deviate slightly after setting the flow level due to relaxation of the flowmeter valve as it equilibrates to its new position. Allow 1-2 minutes for the pressure to stabilize after setting the flowrate.

### GENERATING PLASMA

- Select the desired RF power level.
- Look through the viewing window for the plasma glow and indication that plasma has formed (*Figure 16* shows an example of an air plasma).

### PLASMA TREATMENT

- Process the sample for the desired duration. The timing of the plasma treatment should begin when the plasma glow is first observed.
- At the end of the process, turn off the RF power.
- Close the process gas cylinder valve(s) and isolation valve(s).
- Allow 1-3 minutes for the vacuum pump to evacuate any residual process gas(es) from the chamber.
- Close the flowmeter valve(s). **DO NOT APPLY EXCESSIVE FORCE WHEN CLOSING THE FLOWMETER VALVES.**
- Close the 3-way valve (lever is vertical, *Figure 17C*).
- If using toxic or reactive gases, see section, *PURGING REACTIVE GASES FROM THE PLASMA CLEANER* for guidelines on purging the Plasma Cleaner with inert gas following plasma treatment.

### VENTING THE CHAMBER

- Turn off the vacuum pump.
- Slowly open the 3-way valve to vent (lever points to the vent flow, *Figure 17B*).
- Once atmospheric pressure is reached, close the 3-way valve (lever is vertical, *Figure 17C*).
- Turn off the PlasmaFlo main power.
- Turn off the Plasma Cleaner main power.
- Open the door and remove the sample.



**CAUTION:**

*To prevent liquid oil backstreaming when using an oil-based vacuum pump, we recommend venting immediately after plasma processing and using a vacuum pump with an inlet check valve, such as those offered by Harrick Plasma.*

## PURGING REACTIVE GASES FROM THE PLASMA CLEANER

If using toxic or reactive gases, the Plasma Cleaner should be purged with inert gas after plasma treatment to avoid releasing the gases into the ambient environment. Note: the procedures outlined below are general guidelines. Consult further with your gas supplier for safe gas handling procedures specific to your gas.

### CONNECTING THE INERT GAS FOR PURGING

The inert gas line should be connected immediately after the process gas regulator output to flush out as much of the process gas line as possible. Example configurations for connecting the inert gas line to the process gas line alongside the plasma system are shown in *Figure 18*.

- Attach an appropriate pressure regulator to the inert gas cylinder, preferably one with an isolation valve at the regulator output.
- Use appropriate tubing and adaptors to connect the inert gas regulator output to the process gas line as close to the process gas regulator output as possible.

#### (A) • Inert Gas Purge (Gas Connected Directly to the Plasma Cleaner)

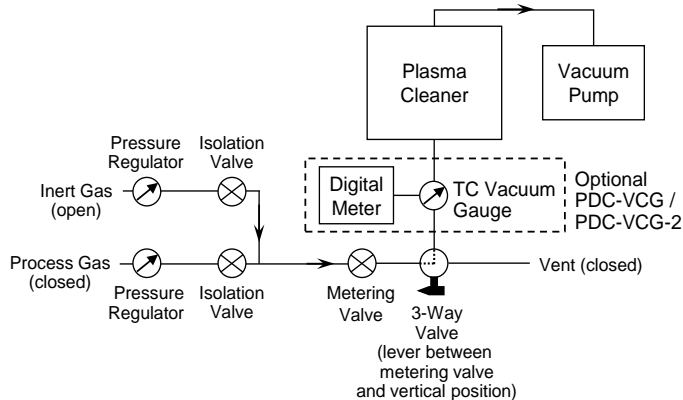

#### (B) • Inert Gas Purge (Using the PlasmaFlo)

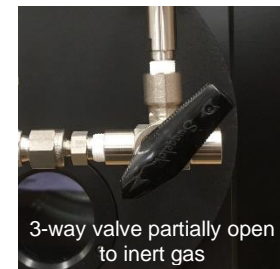
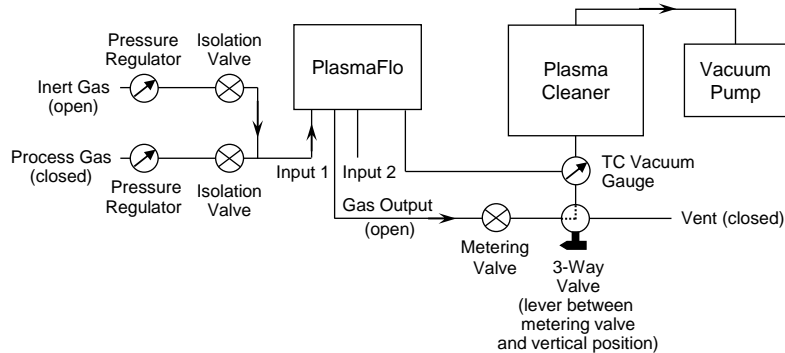

FIGURE 18 • Example Configurations for Inert Gas Purge in the Plasma System



## **PURGING REACTIVE GASES FROM THE PLASMA CLEANER**

### **PURGING WITH INERT GAS AFTER PLASMA TREATMENT**

(Gas Connected Directly to the Plasma Cleaner)

To purge the process gas line and Plasma Cleaner with inert gas following the plasma treatment step described in the previous section, *PLASMA PROCESSING: PROCESSING WITH AIR OR GAS CONNECTED DIRECTLY TO THE PLASMA CLEANER*:

- Check that the process gas cylinder valve and its isolation valve are closed.
- Check that the 3-way valve is closed (lever is vertical, *Figure 15C*).
- Open the metering valve.
- Open the inert gas cylinder valve. Adjust the inert gas pressure regulator to 10 psig. Slowly open the inert gas regulator isolation valve.
- Partially open the 3-way valve to inert gas (lever is intermediate to metering valve and vertical position, *Figure 18A*) and allow the inert gas to flow for up to 5 seconds. If using the optional PDC-VCG / PDC-VCG-2, the vacuum pressure should quickly increase.
- Close the 3-way valve (lever is in vertical, *Figure 15C*). If using the optional PDC-VCG / PDC-VCG-2, the vacuum pressure should gradually decrease.
- Repeat the previous 2 steps of partially opening and closing the 3-way valve to inert gas flow. Repeat a third time. At the end of this procedure, the 3-way valve should be closed (lever is vertical, *Figure 15C*).
- Close the inert gas cylinder valve and inert gas regulator isolation valve.
- Allow 1-3 minutes for the vacuum pump to evacuate any residual gas from the chamber.
- Turn off the vacuum pump.
- Slowly open the 3-way valve to vent (lever points to vent, *Figure 15B*).
- Once atmospheric pressure is reached, close the 3-way valve (lever is vertical, *Figure 15C*).
- Turn off the Plasma Cleaner main power.
- Open the door and remove the sample.

## **PURGING REACTIVE GASES FROM THE PLASMA CLEANER**

### **PURGING WITH INERT GAS AFTER PLASMA TREATMENT** (Using the PlasmaFlo)

To purge the process gas line, PlasmaFlo, and Plasma Cleaner with inert gas following the plasma treatment step described in the previous section, *PLASMA PROCESSING: PROCESSING WITH GAS USING THE PLASMAFLO*:

- Check that the process gas cylinder valve and its isolation valve are closed.
- Check that the 3-way valve is closed (lever is vertical, *Figure 17C*).
- On the PlasmaFlo, check that the flowmeter valves are closed. **DO NOT APPLY EXCESSIVE FORCE WHEN CLOSING THE FLOWMETER VALVES.**
- Open the metering valve.
- Open the inert gas cylinder valve. Adjust the inert gas pressure regulator to 10 psig. Slowly open the inert gas regulator isolation valve.
- On the PlasmaFlo, slowly open the flowmeter valve that is connected to the inert gas line to the highest flow capacity.
- Partially open the 3-way valve to inert gas (lever is intermediate to metering valve and vertical position, *Figure 18B*) and allow the inert gas to flow for up to 5 seconds. The vacuum pressure should quickly increase.
- Close the 3-way valve (lever is vertical, *Figure 17C*). The vacuum pressure should gradually decrease.
- Repeat the previous 2 steps of partially opening and closing the 3-way valve to inert gas flow. Repeat a third time. At the end of this procedure, the 3-way valve should be closed (lever is vertical, *Figure 17C*).
- Close the inert gas cylinder valve and regulator isolation valve.
- Allow 1-3 minutes for the vacuum pump to evacuate any residual gas from the chamber.
- Close the flowmeter valve. **DO NOT APPLY EXCESSIVE FORCE WHEN CLOSING THE FLOWMETER VALVES.**
- If necessary, repeat the above steps with the second process gas.
- Turn off the vacuum pump.
- Slowly open the 3-way valve to vent (lever points to vent, *Figure 17B*).
- Once atmospheric pressure is reached, close the 3-way valve (lever is vertical, *Figure 17C*).
- Turn off the Plasma Cleaner main power.
- Turn off the PlasmaFlo main power.
- Open the door and remove the sample.



This page intentionally left blank.

**MAINTENANCE  
REQUIREMENTS**

For most plasma processes, the Plasma Cleaner requires minimal maintenance. The vacuum pump does require routine servicing. Review the pump manual to determine the maintenance requirements for the vacuum pump.

Some combinations of gas and sample materials may generate particulates and contaminants that can accumulate on the chamber wall. Over time, these contaminants may alter the effectiveness of the plasma process. If a change to the plasma performance or plasma intensity is detected, the chamber may require cleaning or replacement.

**CAUTION:**

*Take all safety precautions and use appropriate personal protection equipment (e.g. gloves, goggles) when cleaning the chamber with solvents or hazardous chemicals.*

**CLEANING THE CHAMBER**

The chamber is made of Pyrex borosilicate glass (standard chamber material) or quartz (optional substitution) and may be cleaned using a standard laboratory glassware cleaner, e.g. Alconox or Liquinox.

- Remove the chamber from the Plasma Cleaner (see *MAINTENANCE: REPLACING THE CHAMBER*).
- Soak the chamber in hot water mixed with Alconox or Liquinox for 24 hours. Use a soft cloth or sponge to clean the chamber. (DO NOT use an abrasive pad).
- Rinse with pure water and allow the chamber to dry completely before installing into the plasma cleaner.
- It may be necessary to clean the chamber multiple times in this manner to resolve performance issues.
- If cleaning the chamber does not resolve the issue, the chamber may need to be replaced. See *APPENDIX B: PLASMA CLEANER REPLACEMENT PARTS* for the appropriate part number.

**REPLACING THE CHAMBER**

To replace the chamber (*Figure 19*):

- Disconnect the vacuum hose from the back of the Plasma Cleaner (*Figure 19A*).
- Loosen the thumbscrew of the retaining ring on the plasma chamber outlet (*Figure 19B*).
- Slide the chamber out (*Figure 19C*).
- Slide the new chamber in.
- Hand-tighten the thumbscrew on the retaining ring.
- Connect the vacuum hose to the plasma chamber outlet. Tighten the hose clamp around the hose.

**(A) • Disconnect the vacuum hose from the plasma chamber outlet**



**(B) • Loosen the thumbscrew of the retaining ring**



**(C) • Slide the chamber out**



**FIGURE 19 • Replacing the Plasma Chamber**

### CLEANING THE PLASMA CLEANER DOOR AND O-RING

To clean the Plasma Cleaner door and o-ring:

- Remove the o-ring from the Plasma Cleaner door (*Figure 20*).
- Wipe the interior of the Plasma Cleaner door with isopropyl alcohol.
- Visually inspect the o-ring. If the o-ring shows signs of degradation (e.g. surface is cracked or worn), replace the o-ring (see *APPENDIX B: PLASMA CLEANER REPLACEMENT PARTS* to find the appropriate part number). If the o-ring appears in good condition, wipe the o-ring with isopropyl alcohol to remove any debris or contaminants on the surface. Allow the o-ring to dry completely.
- Reinsert the o-ring into the circular groove on the Plasma Cleaner door. Make sure the o-ring is properly seated in the groove.



**FIGURE 20 • Removing the O-Ring on the Plasma Cleaner Door**

**REPLACING THE WINDOW  
AND WINDOW O-RING**

- Remove the three (3) screws securing the retaining ring to the window (*Figure 21A*).
- Remove the retaining ring (*Figure 21B*).
- Remove the window (*Figure 21C*).
- Remove the o-ring (*Figure 21D*) and visually inspect for any signs of degradation (surface is cracked or worn). Replace the o-ring if needed (see *APPENDIX B: PLASMA CLEANER REPLACEMENT PARTS* for part number). If the o-ring is in good condition, wipe the o-ring with isopropyl alcohol to remove any surface debris. Allow the o-ring to dry completely.
- Reinsert the o-ring into the circular groove. Make sure the o-ring is properly seated in the groove.
- Insert the new window with the UV-coated side facing you (facing away from the chamber). Look for an arrow on the side (ground edge) of the window, which points to the UV-coated side.
- Reinsert the retaining ring. Secure the retaining ring with the three (3) screws.

**(A) • Remove the three (3) screws**



**(B) • Remove the retaining ring**



**(C) • Remove the window**



**(D) • Remove the o-ring**



**FIGURE 21 • Replacing the Window on the Plasma Cleaner Door**

### **CHECKING AND REPLACING THE FUSES**

- Remove the fuse holder at the back of the Plasma Cleaner (*Figure 3B* or *Figure 4B*).
- Check the fuse either visually or using a digital multimeter:  
If the fuse is in working condition, the metal wire inside the fuse should be intact and the digital multimeter should indicate an electrical short across the fuse (resistance of 1 ohm or less).  
If the fuse is blown, the metal wire inside the fuse may be broken and the digital multimeter should indicate an electrical open across the fuse (resistance overload (OL)).
- Replace the blown fuse(s). Refer to *APPENDIX B: REPLACEMENT FUSES* for specifications on the replacement fuse(s).
- Reinsert the fuse holder into the back of the Plasma Cleaner.





This page intentionally left blank.



MALFUNCTION	POSSIBLE CAUSES	CORRECTIVE ACTIONS
<p>Plasma degrades in effectiveness of surface treatment.</p>	<p>Contaminants from previous use have deposited on the plasma chamber walls and door interior.</p>	<p>Plasma chamber and/or door requires cleaning. See <i>MAINTENANCE: CLEANING THE CHAMBER</i> and <i>MAINTENANCE: CLEANING THE PLASMA CLEANER DOOR AND O-RING</i>.</p>
<p>On the PlasmaFlo, the float becomes stuck along the flowtube of the flowmeter.</p>	<p>Dust/particulates or condensation in the flowtube is causing the float to stick.</p>	<p>The clearance (spacing) between the float and inner wall of the flowtube is very small (less than 0.5 mm) in order to achieve such low flowrates. Any dust, particulates, or condensation that may have formed from temperature fluctuations during shipping can cause the float to stick.</p> <p>To free the float: disconnect the gas lines at the PlasmaFlo gas input and output. Open the flowmeter valve fully, Blow clean, dry compressed air or inert gas through the PlasmaFlo gas input until the float moves freely along the flowtube.</p> <p>To prevent dust or condensation from accumulating in the flowtubes, use only dry, clean gas with the PlasmaFlo.</p> <p>If the float continues to stick, contact Harrick Plasma.</p>
<p>On the PlasmaFlo, the flowmeter valve cannot turn or no longer can control the gas flowrate (float does not respond to valve adjustment).</p>	<p>The threads on the flowmeter valve are damaged or stripped.</p>	<p>The flowmeter valve needs to be replaced. Contact Harrick Plasma for a replacement valve and installation instruction.</p> <p>The flowmeter valve is meant only for fine control of the gas flow rate and is not intended for use as shut-off or isolation valve.</p> <p><b>DO NOT APPLY EXCESSIVE FORCE WHEN CLOSING THE FLOWMETER VALVES.</b></p>



## **WARRANTY INFORMATION**

### **DISCLAIMER**

The Plasma Cleaner is designed for safe and efficient operation when used properly and in accordance with the instructions. Failure to observe the following precautions could result in serious personal injury: The Plasma Cleaner is an electrical instrument; to avoid electric shock, please observe all standard precautions, such as not operating the device near water and operating the device at appropriate line voltage and frequency. Do not remove cover plates or housing, except by certified electronics technician. Do not open the Plasma Cleaner door when the chamber is under vacuum. Do not use the Plasma Cleaner near flammable materials. Do not plug vacuum pumps whose input electrical current requirement exceeds 7 Amps into the Plasma Cleaner. With respect to vacuum pumps, please refer to the pump user's manual for specific precautions. In general, for oxygen process gas, an oxygen compatible pump should be used; in case of using toxic gases or gases that ionize to toxic products, an efficient pump exhaust filter should be used. Harrick Plasma shall not be held liable for any damages: indirect or consequential related to this product including loss of revenue. Furthermore, Harrick Plasma's liability shall not exceed the cost of the product. Operational instructions should be followed at all times.

### **WARRANTY**

All products manufactured by Harrick Plasma come with a 1 year limited warranty. Any product failure that results from use in accordance with manufacturers guidelines is covered under the warranty. Any failure resulting from misuse of the product or resulting from actions such a dropping the unit or damage in poor storage conditions, for example, will not be repaired or replaced under warranty. Furthermore, products that have been intentionally damaged cannot be replaced or repaired under warranty. Products out of warranty or not subject to these conditions may be repaired by the manufacturer as a billed service at the manufacturer's discretion. With the exception of this exclusive warranty, Harrick Plasma makes no warranties, explicit or implied. We also disclaim any implied warranties of merchantability or fitness for a particular purpose.

### **REPAIR RETURNS**

Owners of products manufactured by Harrick Plasma in need of service or repair should contact Harrick Plasma prior to return of equipment, regardless of warranty coverage status. Products out of warranty may be repaired by the manufacturer as a billed service at the manufacturer's discretion. Any potentially hazardous substances must be removed from the plasma chamber interior if these items are to be returned with the product. Products to be repaired out of warranty will be initially evaluated and a formal repair estimate will be prepared for approval prior to any repairs being carried out. Any product returned for repair must be accompanied by a repair return document providing contact information, return shipping address and a description of product problems at issue and any measures taken.

### **NEW EQUIPMENT RETURNS**

Recently purchased products manufactured by Harrick Plasma may be returned within 30 days of receipt. Products must be returned in unused, resalable condition, in original packing materials, and are subject to a 15% restocking fee. Vacuum pumps and accessories must be returned within 15 days of receipt in unused, resalable condition, in original packing materials, and are also subject to a 15% restocking fee. Purchasers wishing to return products should contact Harrick Plasma prior to returning.



## SPECIFICATIONS

### ***PDC-001-HP / PDC-002-HP HIGH POWER EXPANDED PLASMA CLEANER***

Chamber Dimensions .....	6" diameter x 6.5" length
Chamber Material .....	Pyrex or Quartz (optional)
Input Power .....	200 W
RF Frequency .....	MHz range
Inlet .....	1/4" Swagelok metering valve
Outlet .....	1/2" OD Pyrex tubing
Weight .....	36 lbs
Dimensions .....	11" H x 18" W x 9" D

### ***POWER APPLIED TO RF COIL***

<b>Low</b> .....	30 W
<b>Medium</b> .....	38 W
<b>High</b> .....	45 W

### ***PDC-VCG / PDC-VCG-2 VACUUM GAUGE AND DIGITAL METER (OPTIONAL)***

Vacuum Pressure Transducer .....	Thermocouple vacuum gauge *
Pressure Range .....	0.001 to 760 Torr
Pressure Accuracy	
0.001 – 0.010 Torr .....	±0.001 Torr
0.010 – 2.00 Torr .....	±15% of reading
2.00 – 160 Torr .....	±50% of reading
160 – 760 Torr .....	±25% of reading
Gas Line Input (optional) .....	1/4" OD hose adaptor at metering valve input
Weight .....	5 lbs
Dimensions .....	5" H x 10" W x 8" D

\* For additional information, see Agilent's RGC-100T Controller User Manual ([www.agilent.com](http://www.agilent.com)).

**PDC-FMG / PDC-FMG-2 PLASMAFLO (OPTIONAL)**

Vacuum Pressure Transducer .....	Thermocouple vacuum gauge *
Pressure Range .....	0.001 to 760 Torr
Pressure Accuracy	
0.001 – 0.010 Torr .....	±0.001 Torr
0.010 – 2.00 Torr .....	±15% of reading
2.00 – 160 Torr .....	±50% of reading
160 – 760 Torr .....	±25% of reading
Number of Gas Inputs .....	2
Flowmeter 1, Flowmeter 2 .....	65 mm reference scale; 50 mL/min maximum flowrate for atmospheric Air (0 psig) **
Flowmeter Accuracy .....	±2% of full scale
Flowmeter Maximum Operating Pressure / Temperature .....	200 psig / 250 °F (121 °C)
Gas Input/Output Connection .....	1/4" Swagelok (three (3) 1/4" OD stainless steel hose adaptors provided)
Output Connection to Plasma Cleaner .....	2-ft. length 1/4" ID flexible tubing with two (2) hose clamps
Weight .....	7 lbs
Dimensions .....	8.5" H x 10" W x 8" D

\* For additional information, see Agilent's RGC-100T Controller User Manual ([www.agilent.com](http://www.agilent.com)).

\*\* Maximum flowrate varies with the process gas and regulated pressure. See *APPENDIX A* for flowrate tables for the most common process gases used with our Plasma Cleaner (Air, Ar, N<sub>2</sub>, O<sub>2</sub>) at 10 psig. Flowrate tables with other process gases and regulated pressures can be made available.

**STANDARD VACUUM PUMPS (for air and inert gases)**
**PDC-VPE / PDC-VPE-2 Basic Vacuum Pump**

Pumping speed 50/60 Hz .....	5.1 m <sup>3</sup> /hr
Ultimate total pressure (gas ballast closed) .....	7.5 mTorr
Ultimate total pressure (gas ballast open) .....	150 mTorr
Inlet .....	1/4" Female BSPP
Outlet .....	1/2" Female BSPP
Motor power 50/60 Hz .....	373 W
Weight .....	27 lbs
Dimensions .....	9.75" H x 14" W x 5.5" D

**OXYGEN SERVICE PUMPS** *(for pure or concentrated oxygen (O<sub>2</sub>) gas)*

***PDC-OPD / PDC-OPD-2 Dry Oxygen Service Pump***

Pumping speed .....	6.2 m <sup>3</sup> /hr
Ultimate total pressure (gas ballast closed) .....	15 mTorr
Ultimate total pressure (gas ballast open) .....	38 mTorr
Inlet / Outlet .....	NW25
Motor power .....	260 W
Weight .....	58 lbs
Dimensions .....	12" H x 17" W x 11" D

***PDC-OPE / PDC-OPE-2 Economy Dry Oxygen Service Pump***

Pumping speed 50/60 Hz .....	3.0/3.6 m <sup>3</sup> /hr
Ultimate total pressure (gas ballast closed; 50/60 Hz) .....	250 mTorr (pump manufacturer specification) *
Inlet .....	NW16
Outlet .....	1/4" Female NPT (10 mm ID hose barb provided)
Motor power 50/60 Hz .....	120 W
Weight .....	21 lbs
Dimensions .....	7" H x 14" W x 5.5" D

\* In our lab tests, ultimate pressures of <100 mTorr were attained.

**FLOWRATE TABLE FOR PLASMAFLO FLOWMETER 1 and FLOWMETER 2 (032-15)**

- Flowmeters with a 65mm reference scale, rather than a direct-read scale, are provided to enable use with a broad range of gases.
- Use the flowrate table below for the specified process gas to convert the millimeter (mm) scale reading on the flowmeters to an actual flowrate (mL/min).

To determine the flowrate:

- Read the position on the millimeter (mm) reference scale that corresponds to the center of the float. Read the float position with the float at eye level.
- Use the correlation table below to convert the float position (mm) to an actual flowrate (mL/min). For example, if argon (Ar) gas, metered at 10 psig regulated pressure, is inputted into Flowmeter 1 (or Flowmeter 2) to raise the float to 35 mm on the reference scale, the corresponding Ar flowrate is 25.0 mL/min.
- The float position may deviate slightly after setting the flow level due to relaxation and equilibration of the flowmeter valve to its new position. Allow a few minutes for the flowrate to equilibrate and the pressure to stabilize.

Flowtube	032-15				
Float Material	Glass				
Gas Temperature	70 °F (21 °C)				
Gas Metering Pressure	Atmospheric pressure (0 psig) and 10 psig for Air; 10 psig for all other gases				
Take readings at the center of the float					
Scale Reading (mm)	Air 0 psig Flow (mL/min)	Air 10 psig Flow (mL/min)	Argon (Ar) 10 psig Flow (mL/min)	Nitrogen (N <sub>2</sub> ) 10 psig Flow (mL/min)	Oxygen (O <sub>2</sub> ) 10 psig Flow (mL/min)
65	48.7	77.1	67.3	72.3	71.7
60	43.8	68.3	58.3	66.3	63.5
55	38.1	59.0	50.9	60.0	54.8
50	32.7	51.5	43.4	51.5	47.0
45	27.9	44.8	37.4	43.7	40.3
40	22.9	38.9	31.5	35.0	34.2
35	19.0	30.7	25.0	28.6	27.0
30	15.5	25.7	20.4	23.1	22.5
25	12.6	20.4	16.6	18.3	18.3
20	9.94	16.2	13.2	13.2	14.1
15	7.27	12.3	9.5	9.7	10.6
10	5.41	9.2	7.3	6.3	7.9
5	3.66	5.7	4.1	4.1	5.1



**AVAILABLE VACUUM PUMPS, OPTIONAL ACCESSORIES,  
REPLACEMENT PARTS AND FUSES**
**AVAILABLE VACUUM PUMPS**

Basic Vacuum Pump, 115V / 230V .....	PDC-VPE / PDC-VPE-2
Basic Vacuum Pump Oil .....	PDC-VPE-OIL
Dry Oxygen Service Pump, 115V / 230V .....	PDC-OPD / PDC-OPD-2
Economy Dry Oxygen Service Pump, 115V / 230V .....	PDC-OPE / PDC-OPE-2
Pump Outlet Connection for PDC-OPF or PDC-OPD .....	PDC-OP-OLT
(includes 9 ft. length exhaust hose; other lengths may be specified)	
Pump Outlet Connection for PDC-OPE .....	PDC-OPE-OLT
(includes 9 ft. length exhaust hose; other lengths may be specified)	

**OPTIONAL ACCESSORIES**

Vacuum Gauge and Digital Meter, 115V / 230V .....	PDC-VCG / PDC-VCG-2
PlasmaFlo Gas Flow Mixer, 115V / 230V .....	PDC-FMG / PDC-FMG-2
Quartz Plasma Chamber .....	PDC-00Q
Quartz Sample Tray (5.5" x 6.5") .....	PDC-00T
Pyrex Sample Tray (5.5" x 6.5") .....	PDC-00T-P

**PLASMA CLEANER REPLACEMENT PARTS**

Pyrex Chamber .....	PDC-191-420
Door O-ring, Viton .....	ORV-438
Inset Window O-ring, Viton .....	ORV-032
Viewing Window .....	001-505
Fluorescent Bulb .....	PDC-FLB

**REPLACEMENT FUSES**

PDC-001-HP High Power Expanded Plasma Cleaner (115V) .....	3 A, slow-blow (2)
PDC-001-HP Vacuum Pump Outlet .....	7 A, slow-blow
PDC-002-HP High Power Expanded Plasma Cleaner (230V) .....	2 A, slow-blow (2)
PDC-002-HP Vacuum Pump Outlet .....	7 A, slow-blow
PDC-VCG / PDC-VCG-2 Vacuum Gauge and Digital Meter .....	0.5 A, slow-blow (2)
PDC-FMG / PDC-FMG-2 PlasmaFlo .....	0.5 A, slow-blow (2)







*Manual Part No. PDC001HP-M-22-01*

*©2022 Harrick Plasma*