

(Go to page 9 to  
Config. control panel)



# 1100°C Box Furnace

Models: BF51600 Series  
BF51700 Series

## Installation and Operation Manual



### Table of Contents

Introduction .....	1
Safety Considerations .....	2
Pre-Installation .....	3
Installation .....	3
Start Up .....	6
Operation – 2132 Controller.....	7
Operation – 91e Controller.....	9
Maintenance .....	10
Troubleshooting .....	14
Replacement Parts and Wiring Diagrams.....	15
Warranty .....	24
Material Safety Data Sheet.....	26

39129H01-RF

© 2000 Lindberg/Blue M  
All rights reserved  
Printed in U.S.A.

## Table of Contents

<b>1</b>	<b>Introduction</b> .....	<b>1</b>
1.1	Features and Benefits .....	1
1.2	Specifications .....	1
<b>2</b>	<b>Safety Considerations</b> .....	<b>2</b>
<b>3</b>	<b>Pre-Installation</b> .....	<b>3</b>
3.1	Unpacking .....	3
3.2	Operating Conditions .....	3
3.3	Atmosphere Systems .....	3
<b>4</b>	<b>Installation</b> .....	<b>3</b>
4.1	Location .....	3
4.2	Wiring .....	3
4.2.1	120 VAC Operation .....	3
4.2.2	240 VAC Operation .....	4
4.2.3	208 VAC Operation .....	4
4.2.4	120 to 208/240 VAC Conversion .....	4
4.3	Exhaust Vent .....	5
4.4	Exhaust Port Connections .....	5
<b>5</b>	<b>Start Up</b> .....	<b>6</b>
5.1	Door Seal Check .....	6
5.2	Furnace Start Up .....	6
<b>6</b>	<b>Operation – 2132 Controller (BF51600 Series)</b> .....	<b>7</b>
6.1	Viewing and Changing the Temperature Setpoint .....	7
6.2	Changing between Celsius and Fahrenheit .....	7
6.3	Auto Tune Operation .....	8
6.4	Viewing Parameter Settings .....	8
6.5	Restoring Factory Set Parameters .....	8
<b>7</b>	<b>91e Control Operation (BF51700 Series)</b> .....	<b>9</b>
7.1	91e Controller .....	9
7.2	Setting the Temperature .....	9
7.3	Setting the Overtemperature Alarm .....	9
7.4	91e Program Parameters .....	9

**8 Maintenance . . . . . 10**

8.1 Thermocouple Replacement . . . . . 10

8.2 Solid-State Relay Replacement . . . . . 11

8.3 Power Relay Replacement . . . . . 11

8.4 Temperature Controller Replacement . . . . . 12

8.4.1 Controller Board Replacement . . . . . 12

8.5 Door Insulation Replacement . . . . . 12

8.6 Heating Unit Replacement . . . . . 13

8.7 Circuit Breaker Replacement . . . . . 13

8.8 Door Seal Adjustment . . . . . 13

**9 Troubleshooting . . . . . 14**

**10 Replacement Parts and Wiring Diagrams . . . . . 15**

**11 Warranty . . . . . 24**

11.1 Domestic Warranty (United States and Canada) . . . . . 24

11.2 International Warranty (excluding Canada)  
12 Months Parts Warranty . . . . . 24

**12 Moldatherm® Insulation Material Safety Data Sheet . . . . . 26**

## 1 Introduction

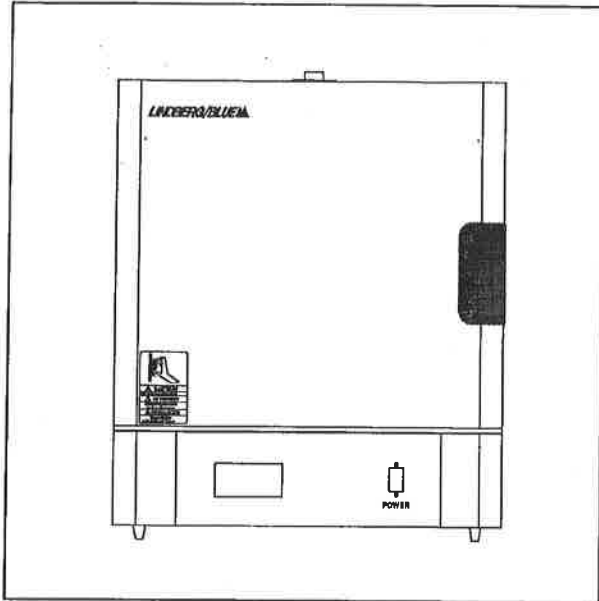

The Lindberg/Blue M BF51600/BF51700 Series is a family of ultra lightweight, economical, laboratory box furnaces. The low thermal mass Moldatherm<sup>®</sup> insulation/heating element provides fast duty cycles, energy conservation, and efficient programming. Refer to Table 1 for specifications.

### 1.1 Features and Benefits

- Controlled heat-up rate eliminates thermal shock to materials.
- Quick heat-up and cool-down rates.
- Four chamber sizes.
- Energy efficient Moldatherm insulation suitable for high interior-exterior temperature differential. The unit is rated for a maximum operating temperature of 1100°C.
- Resists attack from most corrosive agents and can be used in atmospheres other than air.
- Side-hinge door for convenient operation.
- Air vent, standard.
- Atmosphere inlet port standard.
- Digital instrumentation for precise temperature setpoint and display. Microprocessor automatically optimizes control parameters during furnace operation.
- Main power ON/OFF switch on control panel.
- Safety interlock switch automatically interrupts power to heating element when door is opened. This feature protects heating element and eliminates operator's exposure to electrical shock.
- Type K thermocouple.

### 1.2 Specifications

Table 1. BF51600 and BF51700 Series Moldatherm Box Furnaces

Model	Dimensions W x F-B x H In. (cm)		Watts	Control Type	Voltage	Net Prod. Wt. lbs (kg)		
	Chamber	Exterior						
BF51648A <sup>a</sup>	4 x 8 x 4 (10.1 x 20.3 x 10.1)	15 x 20 x 17.5 (38.1 x 50.8 x 44.4)	1,800	Single Setpoint	120/208/240 VAC 50/60 Hz, 1 phase	45 (20.4)		
BF51648C <sup>a</sup>				Microprocessor Control				
BF51748A <sup>a</sup>				Single Setpoint				
BF51748C <sup>a</sup>				Microprocessor Control				
BF51666A <sup>a</sup>	6 x 9 x 6 (15.2 x 22.8 x 15.2)	17 x 21 x 21.5 (43.1 x 53.3 x 54.6)	1,800	Single Setpoint	120/208/240 VAC 50/60 Hz, 1 phase	65 (29.5)		
BF51666C <sup>a</sup>				Microprocessor Control				
BF51766A <sup>a</sup>				Single Setpoint				
BF51766C <sup>a</sup>				Microprocessor Control				
BF51694C <sup>b</sup>	9 x 14 x 9 (22.8 x 35.6 x 22.8)	21 x 25.75 x 26 (53.3 x 65.4 x 66)	3,500	Single Setpoint	208/240 VAC 50/60 Hz, 1 phase	97 (44.0)		
BF51794C <sup>b</sup>				Microprocessor Control				
BF51628C	12 x 18 x 12 (30.5 x 45.7 x 30.5)	24 x 30 x 28 (60.1 x 76.2 x 71.1)	5,600	Single Setpoint			208/240 VAC 50/60 Hz, 1 phase	142 (64.4)
BF51728C				Microprocessor Control				

<sup>a</sup> Voltage Code: A – 120V Model; C – 208/240V Model. "A" models are equipped with power cord and plug for 120 VAC operation. "C" models are equipped with power cord and plug for 208/240 VAC operation.

<sup>b</sup> Equipped with power cord and plug for 240 VAC operation.

## 2 Safety Considerations



**WARNING!** Do not modify or use equipment in a manner other than expressly intended. Modification of equipment other than that for which it is explicitly designed could cause severe injury or death. Any customer after-market retrofit violates the warranty of the equipment.

Do not reconfigure the controller. Any reconfiguration of the control instrument could cause inaccurate readings, faulty instrument values, and may cause the unit to become overheated and start on fire, causing personal injury or death, product and property damage.

Do not modify or disconnect any safety features provided. Disconnection of the unit safety features could allow the unit to become overheated and start on fire, causing personal injury or death, product and property damage.

Do not use components or materials not specifically designed for this equipment. Failure to comply with this precaution could result in damage to equipment used or the oven and may create an overheat situation. Also, do not use anything other than OEM exact replacement equipment and parts. Not using OEM replacement parts could cause faulty instrumentation readings, inoperable equipment, or temperature overshoot. Both situations may cause personal injury or death, product, and property damage.

Before using, user shall determine the suitability and integrity of the product for the intended use and that the unit has not been altered in any way. Misapplication may compromise the safety of the end user or the life of the product.



**CAUTION!** This product contains refractory ceramic fiber which can result in the following:

- May be irritating to skin, eyes, and respiratory tract.
- May be harmful if inhaled.
- May contain or form cristobalite (crystalline silica) with use at high temperature (above 871°C) which can cause severe respiratory disease.
- Possible cancer hazard based on tests with laboratory animals. Animal studies to date are inconclusive. No human exposure studies with this product have been reported.



**WARNING!** Before maintaining this equipment, read the applicable MSDS (Material Safety Data Sheets) at the back of this manual.



**WARNING!** When installing, maintaining, or removing the fiberglass insulation, the following precautions will minimize airborne dust and fiber:

- Keep personnel not involved in the installation out of the area.
- Use a good vacuum to clean area and equipment. Use a dust suppressant if sweeping is necessary. Do not use compressed air.
- Use a disposable mask suitable for nuisance dust.
- Wear long sleeve clothing, gloves, hat, and eye protection to minimize skin and eye contact. Do not wear contact lenses.
- Thoroughly wash self after work is complete.
- Launder work clothing separate from other clothes and thoroughly clean laundering equipment after use. If clothing contains a large amount of dust and/or fiber, dispose of rather than clean.
- Promptly place used fiberglass parts and dust in plastic bags and dispose of properly.

### 3 Pre-Installation

#### 3.1 Unpacking

Carefully unpack and inspect the unit and all accessories for damage. If you find any damage, keep the packing materials and immediately report the damage to the carrier. We will assist you with your claim, if requested. **Do not return goods to Lindberg/Blue M without written authorization.** When submitting a claim for shipping damage, request that the carrier inspect the shipping container and equipment.

#### 3.2 Operating Conditions

High concentrations of sulfates, chlorides, fluorides, alkalis, and  $V_2O_5$  can have corrosive effects on the ceramic fiber. Contact Lindberg/Blue M for additional information about the effects of specific atmospheres on furnace performance.

With prolonged use, hairline cracks can develop in the insulation materials. These minor cracks will not affect the furnace's performance. We recommend turning off the furnace completely when not in use. The heating unit is not damaged by rapid heating and cooling cycles.

#### 3.3 Atmosphere Systems

The BF51600 and BF51700 Series furnaces are not designed for use with combustible or inert atmospheres requiring an air tight chamber. If an exhaust port is used, the furnace should not be located in an enclosed area without proper ventilation.



**WARNING!** Do not use combustible gases in this furnace.



**CAUTION!** Avoid combustible products which generate toxic or hazardous vapor or fumes. Work should only be done in a properly vented environment.

### 4 Installation

Do not exceed the electrical and temperature ratings printed on the dataplate of the furnace.



**CAUTION!** Improper operation of the furnace could result in dangerous conditions. To preclude hazard and minimize risk, follow all instructions and operate within design limits noted on the dataplate.

#### 4.1 Location

Install the furnace in a level area free from vibration. To permit proper air flow, leave at least three inches of space on all sides of the unit and 12 inches above the unit.

#### 4.2 Wiring

For detailed wiring information, refer to the wiring diagrams in Section 10 on page 15.

##### 4.2.1 120 VAC Operation

The BF51648A, BF51748A, BF51666A, and BF51766A models operate on 120 VAC, 50/60 Hz, single phase. Each furnace includes a 120 VAC grounded plug and cord set. The units are completely prewired and ready for operation.

Before initial start up, inspect the furnace's wiring connections:

1. Remove the corner screws on the back panel of the furnace and detach the back panel.
2. Check that the thermocouple is securely mounted and undamaged.
3. Check the thermocouple wiring connections. Refer to Figure 1 on page 3. Red is always negative.



**CAUTION!** Failure to check thermocouple wiring connections before initial start up could result in damage to the furnace.

4. Check that all electrical connections are secure. Visually check that the door stop bracket properly contacts the power interrupt switch near the front of the furnace.

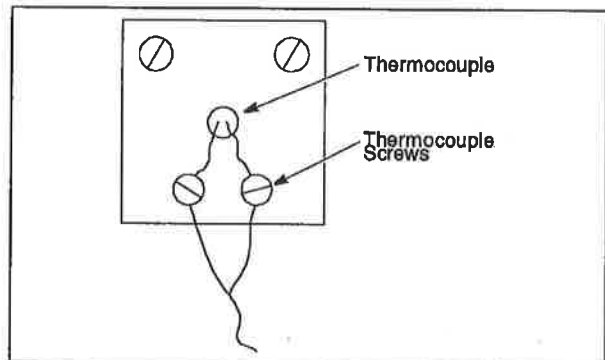

Figure 1. Thermocouple

5. Replace the back panel on the furnace and secure with the corner screws.
6. Plug the line cord into a 120 VAC, 20 amp, grounded line. The furnace draws approximately 15 amps (1800 W) for models BF51648, BF51748, BF51666, and BF51766.

#### 4.2.2 240 VAC Operation

The BF51648C, BF51748C, BF51666C, BF51766C, BF51694C, BF51794C, BF51628C, and BF51728C models are 240 VAC furnaces.

Follow the procedure in Section 4.2.2.1 for BF51648C, BF51748C, BF51666C, BF51766C, BF51694C, and BF51794C models and the procedure in Section 4.2.2.2 for BF51628C and BF51728C models.

##### 4.2.2.1 BF51648C, BF51748C, BF51666C, BF51766C, BF51694C, and BF51794C Models

The BF51648C, BF51748C, BF51666C, BF51766C, BF51694C, and BF51794C models include a 240 VAC grounded plug and cord set. The units are completely prewired and ready for operation.

Before initial start up, inspect the furnace's wiring connections:

1. Remove the corner screws on the back panel of the furnace and detach the back panel.
2. Check that the thermocouple is securely mounted and undamaged.
3. Check the thermocouple wiring connections. Refer to Figure 1 on page 3. Red is always negative.



**CAUTION!** Failure to check thermocouple wiring connections before initial start up could result in damage to the furnace.

4. Check that all electrical connections are secure. Visually check that the door stop bracket properly contacts the power interrupt switch near the front of the furnace.
5. Replace the back panel on the furnace and secure with the corner screws.
6. Plug the line cord into a 240 VAC, 20 amp, grounded line.

##### 4.2.2.2 BF51628C and BF51728C Models

The BF51628C and BF51728C 240 VAC furnaces do not include a 240 VAC grounded plug and cord set.

Furnace installation requires two power wires and one ground wire (not provided). The required power wire size is 10 GA, 23.3 amps @ 240V.

To connect the furnace to the power source, complete the following steps:

1. Determine the length of wire needed to connect the furnace to the power source.
2. Label the power wires *Line 1* and *Line 2* and label the ground wire *Ground*.
3. Remove the two outlet box cover screws. Remove the outlet box cover.
4. Punch out the 7/8 inch knockout in the outlet box cover.
5. Thread the Line 1, Line 2, and Ground wires through the 7/8 inch knock-out. Use wire nuts to connect the wires to the appropriate screws:

Wire	Label
Line 1	L1
Line 2	L2
Ground	GND

6. Check that the thermocouple is securely mounted and undamaged. Check the thermocouple wiring connections. Refer to Figure 1. Red is always negative.



**CAUTION!** Failure to check thermocouple wiring connections before initial start up could result in damage to the furnace.

7. Check that all electrical connections are secure. Visually check that the door stop bracket contacts the power interrupt switch near the front of the furnace.
8. Place the back panel on the furnace and secure with the corner screws.

#### 4.2.3 208 VAC Operation

Lindberg/Blue M Moldatherm box furnace heating elements are specifically designed for operation on 120, 208, or 240 VAC. A furnace wired for 240 VAC operation can also operate on 208 VAC. However, heatup and recovery times will be longer.

##### 4.2.4 120 to 208/240 VAC Conversion

Although the BF51648A, BF51748A, BF 51666A, and BF51766A models are factory wired to operate on 120 VAC, they can be converted to 208/240 VAC operation.

The conversion procedure requires replacing the power relay and changing the jumper configuration of the elements. If you plan to convert from 120 VAC to 208/240 VAC operation, please contact the service department.

### 4.3 Exhaust Vent

Flow from the exhaust vent on the top of the unit can be adjusted by inserting or removing the plug provided.

For most applications, the exhaust vent should be fully plugged during operation of the furnace; a closed vent results in more efficient operation and greater temperature stability. However, there are some applications which benefit from a partially or fully open exhaust vent.

The exhaust vent should be partially or fully open for the following applications:

- To provide slow cool down of work load. Some work loads may be damaged by heat shock when the furnace door is opened. The vent can be opened to allow work load to cool gradually.
- To remove unwanted vapors and gases from the furnace chamber. If you need to ventilate vapors and gases outside of the room, be sure to read Section 4.4.

Figure 2 shows how you can use the plug to adjust flow from the exhaust vent.

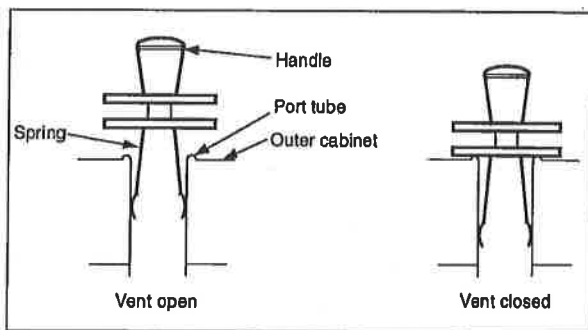

Figure 2. Exhaust Vents

### 4.4 Exhaust Port Connections

The one inch diameter exhaust port through the top wall of the furnace allows for the removal of unwanted vapors and gases produced during high-temperature operation.

When you need to ventilate vapors and gases outside of the room, be sure to make a proper connection to the exhaust port that allows some room air to flow into the exhaust. This is necessary to prevent "chimney effect" which sucks heat out of the chamber and results in slow run-up time or poor temperature uniformity.

Two methods of making the exhaust port connection are shown in Figure 3 below. With a hood suspended above the furnace, be sure that there is at least three inches between the hood and the exhaust port. If you use a metal tube or pipe leave at least one inch clearance.

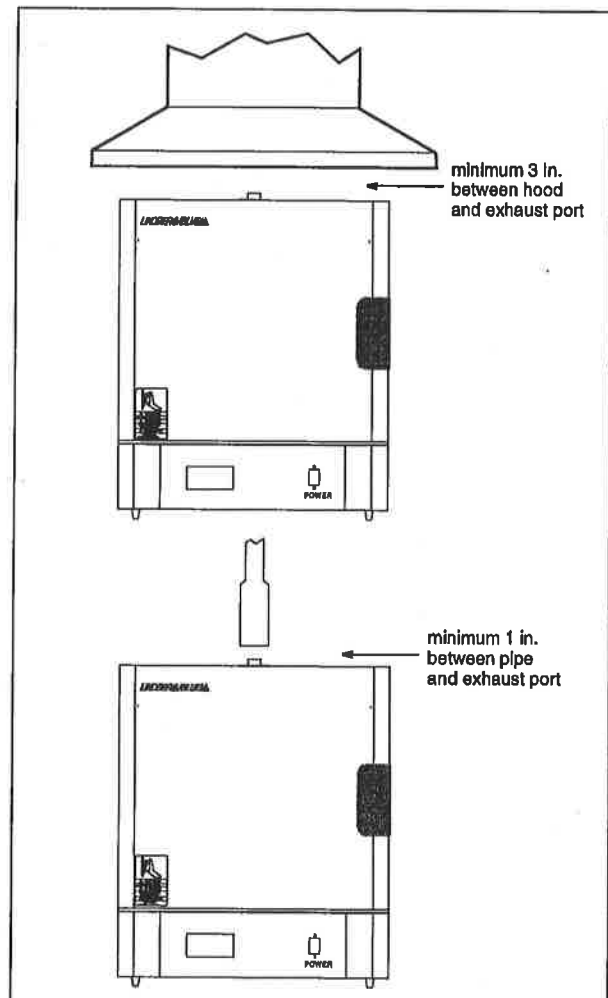

Figure 3. Preventing Chimney Effect



## 5 Start Up



**CAUTION!** Observe the following precautions when operating the furnace:

- Never stand in front of an open furnace.
- Wear protective eyewear.
- Wear protective gloves.
- Use tongs to insert and remove furnace load.
- Do not allow the load to touch the furnace walls.
- Always use a hearth plate on the furnace bottom.



**WARNING!** Before operating this equipment, read the applicable MSDS (Material Safety Data Sheets) at the back of this manual.



**WARNING!** When installing, maintaining, or removing the refractory insulation, the following precautions will minimize airborne dust and ceramic fiber:

- Keep personnel not involved in the installation out of the area.
- Use a good vacuum to clean area and equipment. Do not use compressed air.
- Use NIOSH high efficiency respirator (3M #8710 or equivalent).
- Wear long sleeve clothing, gloves, hat, and eye protection to minimize skin and eye contact. Do not wear contact lenses.
- Thoroughly wash self after work is complete.
- Launder work clothing separate from other clothes and thoroughly clean laundering equipment after use. If clothing contains a large amount of dust and/or ceramic fiber, dispose of rather than clean.
- Promptly place used ceramic fiber parts and dust in plastic bags and dispose of properly.

### 5.1 Door Seal Check

*It is very important to check the door seal before using this furnace. Door seal integrity is essential to maintain temperature uniformity and prevent fumes being released into the area surrounding the furnace.*

To check the door seal:

1. With the furnace power off and chamber cold, open the door.
2. Insert a strip of paper (a couple of inches wide) between the door insulation and the chamber opening. Do not position the paper in the corner of the chamber. Close the door.
3. Slowly pull the paper strip from the outside. You should feel some resistance. If the paper does not pull out, this area of the door seal may be causing a gap in another area of the door seal.
4. Repeat this test at 2-inch intervals around the door. If the door does not seal properly, a door adjustment must be done (see Section 8.8 on page 13).

### 5.2 Furnace Start Up

The furnace has a power interrupt switch. Opening the furnace door shuts off power to the heating unit. The door must be completely closed before the furnace will operate.

To start up the furnace, complete the following steps:

1. Turn furnace ON.
2. Use the arrow keys to adjust the setpoint to 200°C.
3. Run the furnace for two hours at 200°C.
4. Check for heat loss through the door. In the event of heat loss, recheck the door seal (refer to Section 5.1).
5. Use the arrow keys to adjust the setpoint to 550°C.
6. Run the furnace for two hours at 550°C.
7. Use the arrow keys to adjust the setpoint to 1,000°C.
8. Run the furnace for two hours at 1,000°C.
9. Adjust setpoint to room temperature.

## 6 Operation – 2132 Controller (BF51600 Series)

The Temperature Controller senses the process temperature of the furnace and supplies the heat necessary to achieve the desired setpoint.

All models in the BF51600 Series use the 2132 controller. Refer to Section 7 for information on the 91e controller used with BF51700 Series models.

The controller includes an LED display and a pushbutton keypad (shown in Figure 4). When you are not using the pushbutton keypad, the process value (actual temperature) always displays. Refer to Table 2 for a list of LED displays and keypad functions.

The temperature controller is configured and tuned at the factory to function well for most applications. Occasionally, it may be advisable to configure the temperature controller differently to suit a particular working environment or process.



**CAUTION!** Before reconfiguring the controller, read this chapter and the *Model 2132 Operation Manual*. Reconfiguring the controller can change the unit characteristics and design parameters, which can hamper performance and make the equipment dangerous to use.

This section provides brief instructions on how to perform the following configuration changes:

- Setting the temperature.
- Changing between Celsius and Fahrenheit.
- Starting the Autotune function
- Restoring factory settings after Autotune.

For more detailed instructions on configuring the temperature controller, refer to the *Model 2132 Operation Manual*.

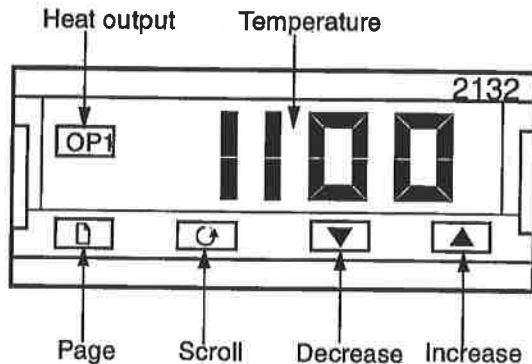

Figure 4. 2132 Control Panel

Table 2. 2132 Pushbutton Keypad Functions

Pushbutton	Description
	The page key advances the display to show units (°C, °F), tuning parameters (Atun), the Pid list, and access to the protected list (ACCS).
	The scroll key advances the display to show the next item within each page. While in the protected list the scroll key advances the display to the next parameter code and setting.
	The up arrow key is used to increase a setpoint or a parameter setting.
	The down arrow key is used to decrease a setpoint or a parameter setting.

### 6.1 Viewing and Changing the Temperature Setpoint

To view the setpoint, press either ▲ or ▼ and release.

To change the setpoint, press and hold either ▲ or ▼ until the desired setpoint shows on the LED display. When the display shows the desired setpoint, release the buttons. After two seconds (during which the controller stores the new value) the display will return to showing the actual temperature.



**CAUTION!** Do not adjust the setpoint above 1100°C (2012°F).

### 6.2 Changing between Celsius (°C) and Fahrenheit (°F)

Changing the displayed units of measure requires paging to the protected list (ACCS), entering the appropriate access codes, and changing the setting of the unit parameter.



**CAUTION!** When changing units of measure, be sure that you follow the steps exactly and that you do not modify any other parameter settings. Changing parameter settings on the protected list (ACCS) can hamper performance and make the equipment dangerous to use.

To change from °C to °F or from °F to °C:

1. Press the page button and release to display ACCS.
2. Press the scroll button once to display codE.
3. Press ▲ to display the number 1. The control program will acknowledge this access code by displaying PASS.
4. Press to display Goto, then press ▲ to display the value conf.
5. Press to display Conf (note the capital "C").
6. Press ▲ to display the number 2. The control program will acknowledge this access code by displaying PASS.
7. Wait two seconds for the display to return from PASS back to Conf.
8. Press once to display inSt, then Press to display unit.
9. Press and release ▲ to display the choices C and F. Once the choice you want is displayed, press the page button to display Exit.
10. Indicate you want to exit by pressing ▲ to display YES. The actual temperature display will return after two seconds.

To verify the units you chose, press and release .

### 6.3 Auto Tune Operation

The factory set parameters are designed to optimize furnace performance under normal operating conditions. If you have unusual conditions or requirements — for example, high ambient temperatures or heavy shelf loading — you can use the Auto Tune function to change the furnace's performance characteristics.



**CAUTION!** Be sure that you analyze current performance carefully before deciding to do an Auto Tune operation.

If you are not satisfied with the results of an Auto Tune operation, you can restore the factory set parameter values by following the instructions in Section 6.5.

Before starting Auto Tune operation, be sure to have the furnace operating with typical load and ambient temperature conditions.

To start Auto Tune:

1. Press and release the page button **⏏** repeatedly until you reach the Atun display.
2. Scroll (**↻**) to display tunE.
3. Press **▲** to display on.
4. Press the **⏏** and **↻** buttons *together* and release. At this point the actual temperature value and tunE will display alternately to indicate that tuning is in progress.

You can interrupt and terminate the Auto Tune operation at any time by scrolling to tunE (steps 1 and 2 above) and pressing **▲** to display OFF.

After two cycles of temperature oscillation, the tuning process is completed, the tuner switches itself off, and the controller resumes normal operation with the new proportional values.

After Auto Tune operation, you can view the changed settings for proportional values by following the steps described below in Section 6.4.

### 6.4 Viewing Parameter Settings

To view the current proportional values:

1. Press and release the page button **⏏** repeatedly until you reach the Pld display.
2. Press and release the scroll button **↻** to display each PID list item.
3. For each item, press **▲** or **▼** to display its current value setting. After two seconds the display will return to the item name.
4. To return to the normal display, press the page button **⏏** repeatedly until actual temperature value shows in the display.

### 6.5 Restoring Factory Set Parameters

The factory set proportional values are shown below in Table 3.

Table 3. Default Factory Parameter Settings

Parameter Code	Default Value	Description
Pb	20	Proportional band.
tl	120	Integral time.
td	30	Derivative time.
Hcb	10	High cutback.
Lcb	10	Low cutback.

If you have changed these settings by means of Auto Tune and have not experienced improved performance, you can restore the factory settings as follows:

1. Press the page button **⏏** and release to display ACCS.
2. Press the scroll button **↻** once to display codeE.
3. Press **▲** to display the number 1. The control program will acknowledge this access code by displaying PASS.
4. Press **↻** to display Goto, then press **▲** to display the value FuLL. The display will return to Goto after one second.
5. Press the page button **⏏** and release to display Pld.
6. Press the scroll button **↻** to display the name of the parameter you want to restore (the first one will be Pb).
7. Press **▲** to display the current setting (the display returns to the parameter name after two seconds).
8. Press **▲** or **▼** until the factory set value is displayed (refer to Table 3).
9. Repeat steps 6 through 8 for each of the remaining parameters tl, td, Hcb, and Lcb.
10. When you have restored all parameter values, press the page button **⏏** to display ACCS.
11. Press the scroll button **↻** once to display codeE.
12. Press **▲** to display PASS.
13. Press **↻** to display Goto.
14. Press **▲** to display the value oPEr.
15. Press the page button **⏏** and release to return to the actual temperature display.

You can verify proportional values at any time by following the steps described in Section 6.4.

## 7 91e Control Operation (BF51700 Series)

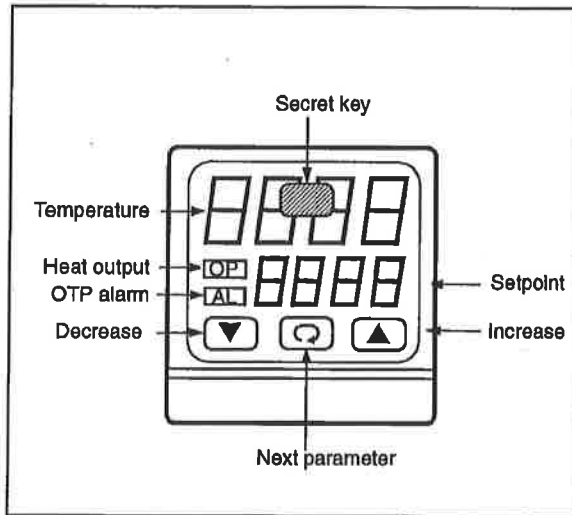

Figure 5. 91e Control Panel

The BF51748A, BF51748C, BF51766A, BF51766C, BF51794C, and BF51728C 1100°C Box Furnace models use the 91e controller. Refer to Section 6 for information on the 2132 controller used with BF51600 Series models.

### 7.1 91e Controller

The 91e controller is a single setpoint controller. You press the arrow keys to establish the setpoint temperature and the furnace heats to that temperature. When larger loads are heated or very low temperatures are required, the controller must be tuned. Refer to the *Model 91e Operation Manual* for detailed instructions.

### 7.2 Setting the Temperature

To set the temperature to the desired setpoint, complete the following steps:

1. Touch any button to illuminate the ▲, ▼, and ↻ keys.
2. Press ▲ or ▼ until the desired setpoint is indicated on the bottom line of the display.

**Note:** The setpoint can be adjusted to any temperature between the SP.HI and SP.Lo factory parameter settings.

### 7.3 Setting the Overtemperature Alarm

To set the alarm on the temperature controller (typically 50°C above the desired main temperature setpoint), complete the following steps:

1. Touch any button to illuminate the ▲, ▼, and ↻ keys. Proceed directly to step 2 if the keys are already lit.
2. Press ↻ until AL.SP appears on the top line of the display.
3. Press ▲ or ▼ until the desired setpoint is indicated on the bottom line of the display.

### 7.4 91e Program Parameters

The 91e controller includes an LED display and a pushbutton keypad. Refer to Table 4 for a list of LED displays and keypad functions. Refer to the *Model 91e Operation Manual* for detailed instructions.

Table 4. 91e Parameter Functions

Indicator	Function
<b>LED Display</b>	
Prop	Proportional bandwidth
Int.t	Integral time constant. OFF and 10 to 2000s.
dEr.t	Derivative time constant. OFF and 1 to 200s.
SP.r	Setpoint ramp rate. 0.1 to 50.0°C/min (0.2 to 90.0°F/min).
SP.HI	Setpoint high limit (max. 1100°)
SP.Lo	Setpoint low limit.
H.ct	Output cycle time. • Logic output: 0.2 to 60.00s. • Relay output: 5.0 to 20s.
LP.br	Loop break reaction time.
Line	Line frequency. 48 to 52 Hz or 58 to 62 Hz.
tunE	Self-tuning feature. Available on demand.
AL.SP	The alarm active display illuminates the red AL light whenever an alarm condition exists.
<b>Pushbutton Keypad</b>	
↻	Parameter access key. Press to scroll through the setup menu parameters.
▲	Increase key increases setpoint or parameter value.
▼	Decrease key decreases setpoint or parameter value.
Secret Key	The secret key (shown in Figure 5) accesses the protected list parameters.

## 8 Maintenance

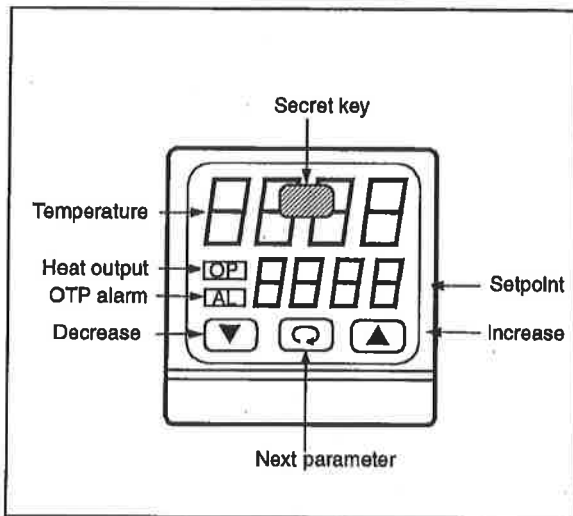

**CAUTION!** Maintenance should only be performed by trained personnel.



**WARNING!** Disconnect furnace from main power before attempting any maintenance to furnace or its controls.



**WARNING!** Before maintaining this equipment, read the applicable MSDS (Material Safety Data Sheets) at the back of this manual.



**WARNING!** When installing, maintaining, or removing the refractory insulation, the following precautions will minimize airborne dust and ceramic fiber:

- Keep personnel not involved in maintenance out of the area.
- Use a good vacuum to clean area and equipment. Do not use compressed air.
- Use NIOSH high efficiency respirator (3M #8710 or equivalent).
- Wear long sleeve clothing, gloves, hat, and eye protection to minimize skin and eye contact. Do not wear contact lenses.
- Thoroughly wash self after work is complete.
- Launder work clothing separate from other clothes and thoroughly clean laundering equipment after use. If clothing contains a large amount of dust and/or ceramic fiber, dispose of rather than clean.
- Promptly place used ceramic fiber parts and dust in plastic bags and dispose of properly.

For replacement parts specifications, refer to Table 6 on page 15.  
For wiring schematics, refer to Section 10 on page 15.

### 8.1 Thermocouple Replacement



**WARNING!** Disconnect furnace from main power before attempting any maintenance to furnace or its controls.

**Note:** For optimal performance, the thermocouple should be replaced once a year. In some situations a more frequent replacement schedule is warranted. SnSr or Sbr on the controller display indicates a broken thermocouple.

Refer to Figure 6 as you perform the following procedure:

1. Remove any atmosphere piping connected to the atmosphere pipe (item #2 in Figure 6).
2. Remove the two screws from the atmosphere pipe. Pull the atmosphere pipe straight out of the furnace.



**CAUTION!** Failure to pull the atmosphere pipe straight out of the furnace will result in damage to the atmosphere pipe or the heating unit.

3. Remove the screws from rear panel corners. Remove the rear panel (item #1 in Figure 6).
4. Note polarity and wire location. Loosen the terminal screws and remove thermocouple lead wires.
5. Remove thermocouple mounting screws.
6. Slide out head and old thermocouple (item #3 in Figure 6).
7. Replace the thermocouple and connect new wires. Be careful not to bend the thermocouple wire. Red is always negative. (If the extension leads are black and white, white is negative).
8. Replace the furnace rear panel.
9. Replace the atmosphere pipe.

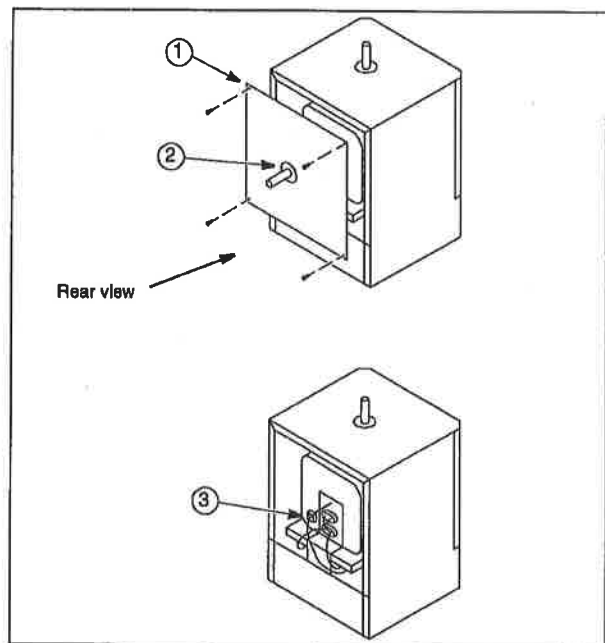

Figure 6. Thermocouple Replacement

## 8.2 Solid-State Relay Replacement



**WARNING!** Disconnect furnace from main power before attempting any maintenance to furnace or its controls.

Refer to the Troubleshooting section for relay testing. If the solid-state relay is inoperable, complete the following steps to replace the relay (refer to Figure 7):

1. Remove the screws located on the left and right sides of the control panel (item #1 in Figure 7).
2. Slide the panel assembly away from the unit to expose components.
3. Locate the solid-state relay on the component tray (item #2 in Figure 7).
4. Note the terminal connections of the relay wires and label them for reattachment. Remove the wires from the terminals of the relay.
5. Remove the mounting screws from the relay.
6. Replace the relay and reconnect the wires.
7. Reassemble the unit.

## 8.3 Power Relay Replacement



**WARNING!** Disconnect furnace from main power before attempting any maintenance to furnace or its controls.

Refer to the Troubleshooting section for power relay testing. If the power relay is inoperable, complete the following steps to replace the relay (refer to Figure 7):

1. Remove the screws located on the left and right sides of the control panel (item #1 in Figure 7).
2. Slide the panel assembly away from the unit to expose components.
3. Locate the power relay on the component tray (item #3 in Figure 7).
4. Note the terminal connections of the relay wires and label them for reattachment. Remove the wires from the terminals of the relay.
5. Remove the mounting screws from the relay.
6. Replace the relay and reconnect the wires.
7. Reassemble the unit.

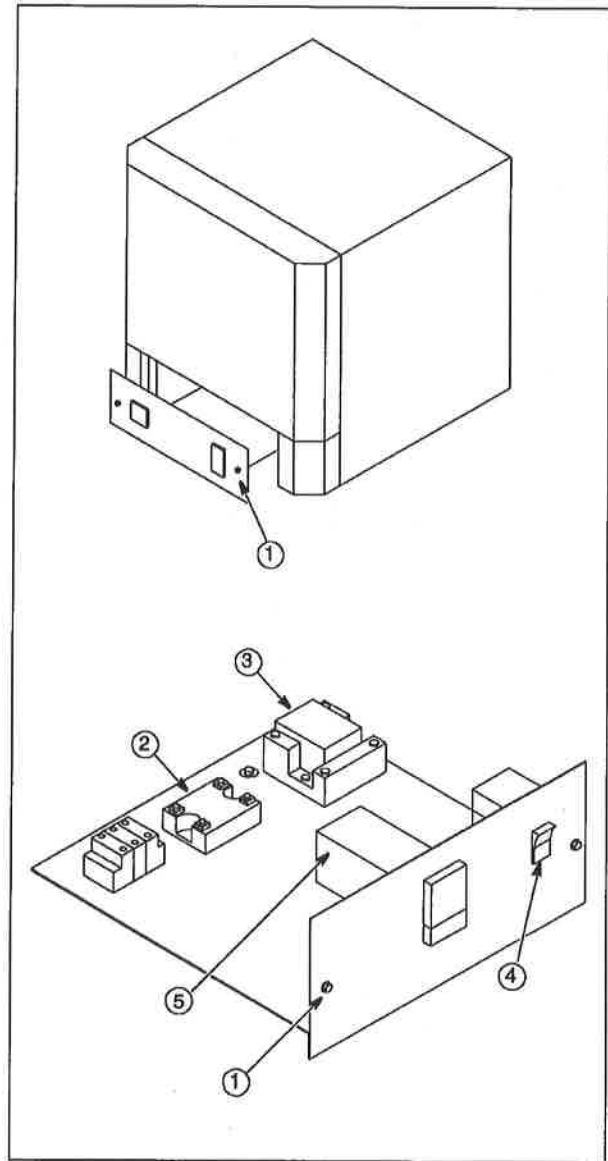

Figure 7. Solid State Relay Replacement

### 8.4 Temperature Controller Replacement



**WARNING!** Disconnect furnace from main power before attempting any maintenance to furnace or its controls.

To replace the entire controller, complete the following steps (refer to Figure 7):

1. Disconnect the main power and switch the circuit breaker (#4 in Figure 7) to the OFF position.
2. Remove the two sheet metal screws located on each side of the furnace near the lower front (#1 in Figure 7). Pull the control panel forward to access the controller (#5 in Figure 7).
3. Note the terminal connections of the wires and label them for reattachment. Remove power input and output wires from the back of the controller. Observe polarity for the thermocouple lead wire. Red is always negative. Refer to Figure 1 on page 3 for additional wiring information.
4. Pull the controller out through the front of the control panel.
5. Install the replacement instrument by reversing the above procedure.

#### 8.4.1 Controller Board Replacement

To replace the controller board *only* (for models that use the 91c and 91p controllers) complete the following steps:

1. Disconnect the main power and switch the circuit breaker (#4 in Figure 7) to the OFF position.
2. Grasp the top and bottom grips on the controller front plate, lightly squeeze the front plate, and pull the plate straight out of the controller sleeve. The controller inner circuit boards will be exposed.
3. Set the old controller aside and insert the replacement controller:
  - a. Grasp the top and bottom grips on the replacement control board front plate and carefully slide the replacement control board into the old sleeve.
  - b. Gently push the replacement control board until it locks (clicks) into the sleeve.



**CAUTION!** Do not apply excessive pressure on the controller boards. Excessive pressure will result in damage to the circuit boards.



**CAUTION!** Do not touch the contacts or other electronic components. Static electricity can damage the chips.

4. Carefully slide the old controller board into the replacement sleeve until the controller board locks into the sleeve.
5. Mark the sleeve defective.

### 8.5 Door Insulation Replacement



**WARNING!** When installing, maintaining, or removing the fiberglass insulation, the following precautions will minimize airborne dust and fiber:

- Keep personnel not involved in the installation out of the area.
- Use a good vacuum to clean area and equipment. Use a dust suppressant if sweeping is necessary. Do not use compressed air.
- Use a disposable mask suitable for nuisance dust.
- Wear long sleeve clothing, gloves, hat, and eye protection to minimize skin and eye contact. Do not wear contact lenses.
- Thoroughly wash self after work is complete.
- Launder work clothing separate from other clothes and thoroughly clean laundering equipment after use. If clothing contains a large amount of dust and/or fiber, dispose of rather than clean.
- Promptly place used fiberglass parts and dust in plastic bags and dispose of properly.

To replace the door insulation, complete the following steps (refer to Figure 8):

1. Open the door completely.
2. Pull the door insulation plug and frame up and out at a 45° angle.
3. Install the new door insulation plug and frame.

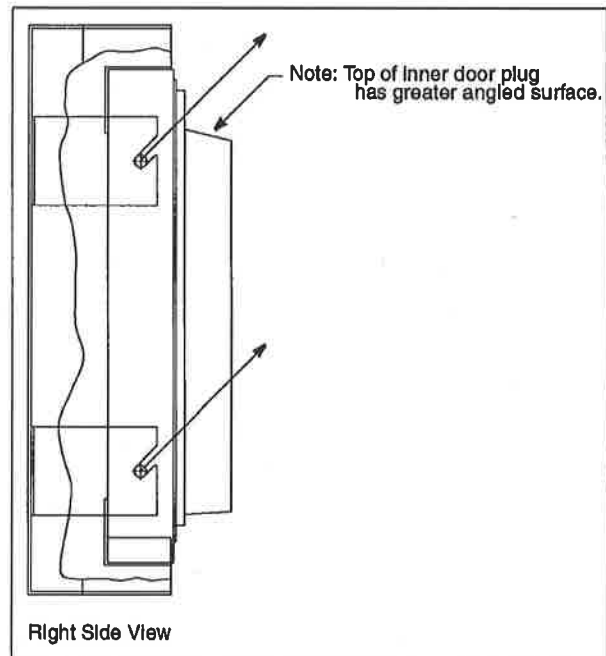

Figure 8. Door Insulation Replacement

## 8.6 Heating Unit Replacement



**WARNING!** Disconnect furnace from main power before attempting any maintenance to furnace or its controls.



**CAUTION!** This product contains ceramic fiber or other refractories which can result in the following:

- May be irritating to skin, eyes, and respiratory tract.
- May be harmful if inhaled.
- May contain or form cristobalite (crystalline silica) with use at high temperature (above 871°C) which can cause severe respiratory disease.
- Possible cancer hazard based on tests with laboratory animals. Animal studies to date are inconclusive. No human exposure studies with this product have been reported.

To replace the heating unit, complete the following steps (refer to Figure 9):

1. Remove any atmosphere piping connected to the atmosphere pipe (item #2 in Figure 9).
2. Remove the two screws from the atmosphere pipe. Pull the atmosphere pipe straight out of the furnace.



**CAUTION!** Failure to pull the atmosphere pipe straight out of the furnace will result in damage to the atmosphere pipe or the heating unit.

3. Remove the screws from corners of the rear panel (#1 in Figure 9).
4. Remove the rear panel to expose the heating unit assembly.
5. Remove the two screws from the exhaust vent. Pull the exhaust vent straight up and out of the furnace.
6. Remove the six corner screws from the shell (#3 in Figure 9).
7. Lift the shell away from the base of the cabinet to expose the entire heating unit.
8. Note the terminal connections of the element wires and label them for reattachment. Loosen the terminal nuts and remove the element wires (#4 in Figure 9).
9. Remove the thermocouple head screws and slide the thermocouple out (#5 in Figure 9).
10. Unhook the spring-bands from the base of the chassis.
11. Replace the heating unit and reassemble the furnace.

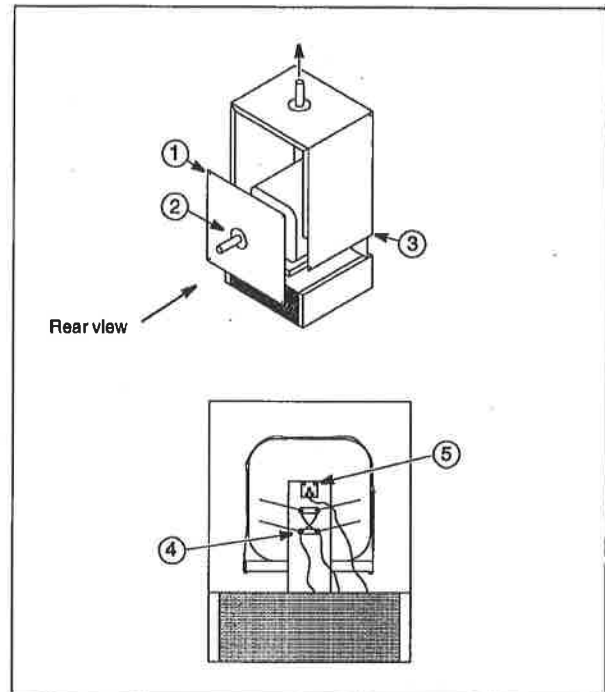

Figure 9. Heating Unit Replacement

## 8.7 Circuit Breaker Replacement

The control circuitry is protected by two circuit breakers located at the rear of the furnace (lower left side). When a circuit breaker opens, a white indicator tab is visible. Check the circuit for faults and press the circuit breaker switch to reset. Replace any circuit breaker which does not reset.

## 8.8 Door Seal Adjustment

The door catch may be causing the door seal to gap on the right side and be okay on the top and bottom. The catch plate can be adjusted using the hex nuts behind the door pull. The door pull can be removed from the right side of the door by prying the edge closest to the magnet catchers.

To make the door seal adjustment:

1. Door assemblies have hex nuts attaching the insulation frame to the outer door frame. Loosen the appropriate nuts and move the door insulation frame to improve the door seal.
2. Recheck the door seal, following the instructions in Section 5.1 on page 6.
3. If a gap is detected only in the center top edge of the door seal, then the top corners of the sealing surface of the door may be sanded to lessen the center gap.
4. After each adjustment recheck the door seal.

The door seal has been adjusted properly if there is no heat loss when operating the furnace up to 500°C.



## 9 Troubleshooting



**WARNING!** Troubleshooting procedures involve working with high voltages which can cause injury or death. Troubleshooting should only be performed by trained personnel.

This section is a guide to troubleshooting furnace problems. Refer to Table 5 for troubleshooting procedures.

**Table 5. Troubleshooting**

Problem	Solution
Controller reads SnSr, Sbr or FAIL	Thermocouple: <ol style="list-style-type: none"> <li>1. Check the thermocouple visually for breaks. If a break is evident, replace thermocouple.</li> <li>2. Check the thermocouple for continuity with an ohmmeter. If there is no continuity, replace thermocouple.</li> <li>3. Check all thermocouple connections. Connections should be clean and free of corrosion.</li> </ol>
Furnace temperature runs away.	Check solid-state relay: <ol style="list-style-type: none"> <li>1. Remove the temperature controller from the furnace.</li> <li>2. Connect power to the furnace. If the heating unit heats, replace the solid-state relay.</li> </ol>
Furnace does not heat.	Front panel red indicator light is on: <ol style="list-style-type: none"> <li>1. If the controller output light is off, check that the setpoint temperature is higher than the furnace display temperature.</li> <li>2. If the controller output light is on, disconnect power from the furnace and check the heating elements for continuity.</li> </ol>
	Front panel red indicator light is off: <ol style="list-style-type: none"> <li>1. Check that the power switch is on.</li> <li>2. Check that the indicator lights on the controller display are on.</li> <li>3. Check that the furnace door is fully closed.</li> <li>4. Check that the door interrupt switch at the middle front of the furnace is engaged when the furnace door is fully closed.</li> <li>5. Check the electrical wires for visible damage. Replace the electrical wires if necessary.</li> <li>6. Check that the Alarm Setpoint on the controller is set higher than the operating temperature (refer to Section 7.3 on page 9).</li> </ol>

## 10 Replacement Parts and Wiring Diagrams

**Table 6. Replacement Parts**

All quantities are one each unless noted.

Furnace Model	BF51648* BF51748*	BF51666* BF51766*	BF51694 BF51794	BF51628 BF51728
Heating Unit	7011-2526-00A	7011-2629-00A	7011-2516-00A	7011-2534-00A
Thermocouple Head	7214-2051-00A	7214-2051-00A	7214-2051-00A	7214-2051-00A
Single Thermocouple	7299-1122-0BA	7299-1122-0BA	7299-1122-0BR	7299-1122-0BR
Hearth Plate	7011-2022-00B	7011-2022-00C	7011-2051-00A	7011-2066-00A
Solid-State Relay	102460	102460	102460	102460
Circuit Breaker	32600-013	32600-013	32600-013	32602-001
Thermocouple Leadwire	(4 ft) 33940-002	(6 ft) 33940-002	(7 ft) 33940-002	(8 ft) 33940-002
Door Insulation	7011-2523-00B	7011-2541-00B	7011-2513-00B	7011-2533-00B
Door Cutout Switch	76887H01	76887H01	76887H01	76887H01
Door Handle	16041	16041	16041	16041
Magnet	16405	16405	16042	(2) 16042
Light, Red	33002-001	33002-001	33002-001	33002-001
Power Relay				
120V Model (A)	16869	16869	N/A	N/A
240V Model (C)	16934	16934	16934	16868
Temperature Controller				
BF51600 Series	300538H01	300538H01	300538H01	300538H01
BF51700 Series	39323H04	39323H04	39323H04	39323H04
Cord Assembly				
120V Model (A)	48951H02	48951H02	N/A	N/A
240V Model (C)	48951H06	48951H06	48951H04	N/A

\* Voltage Code  
A – 120V Model  
C – 208/240V Model

The following pages contain the wiring schematics for all BF51600 and BF51700 models.



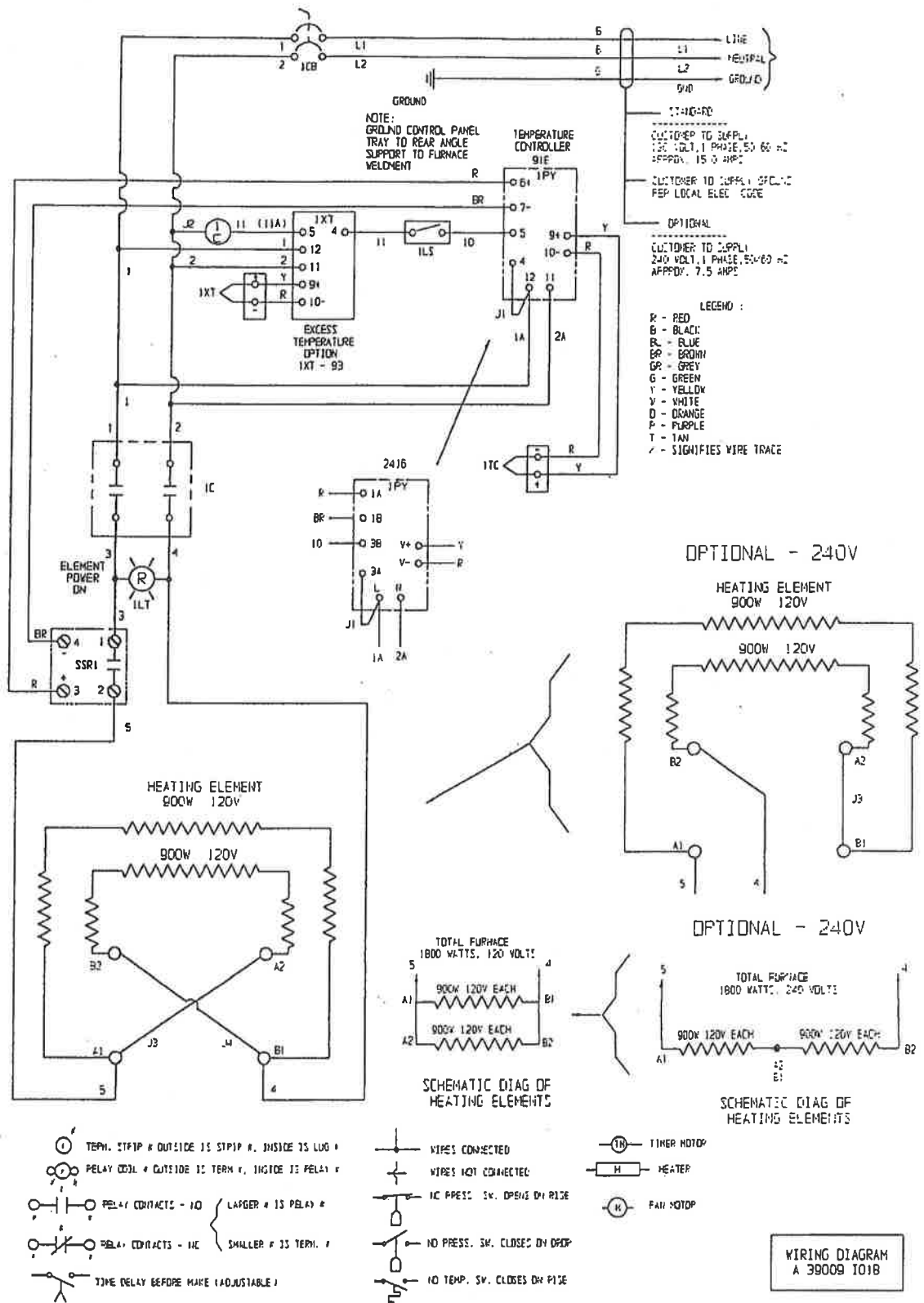

Figure 11. BF51748A and BF51748C

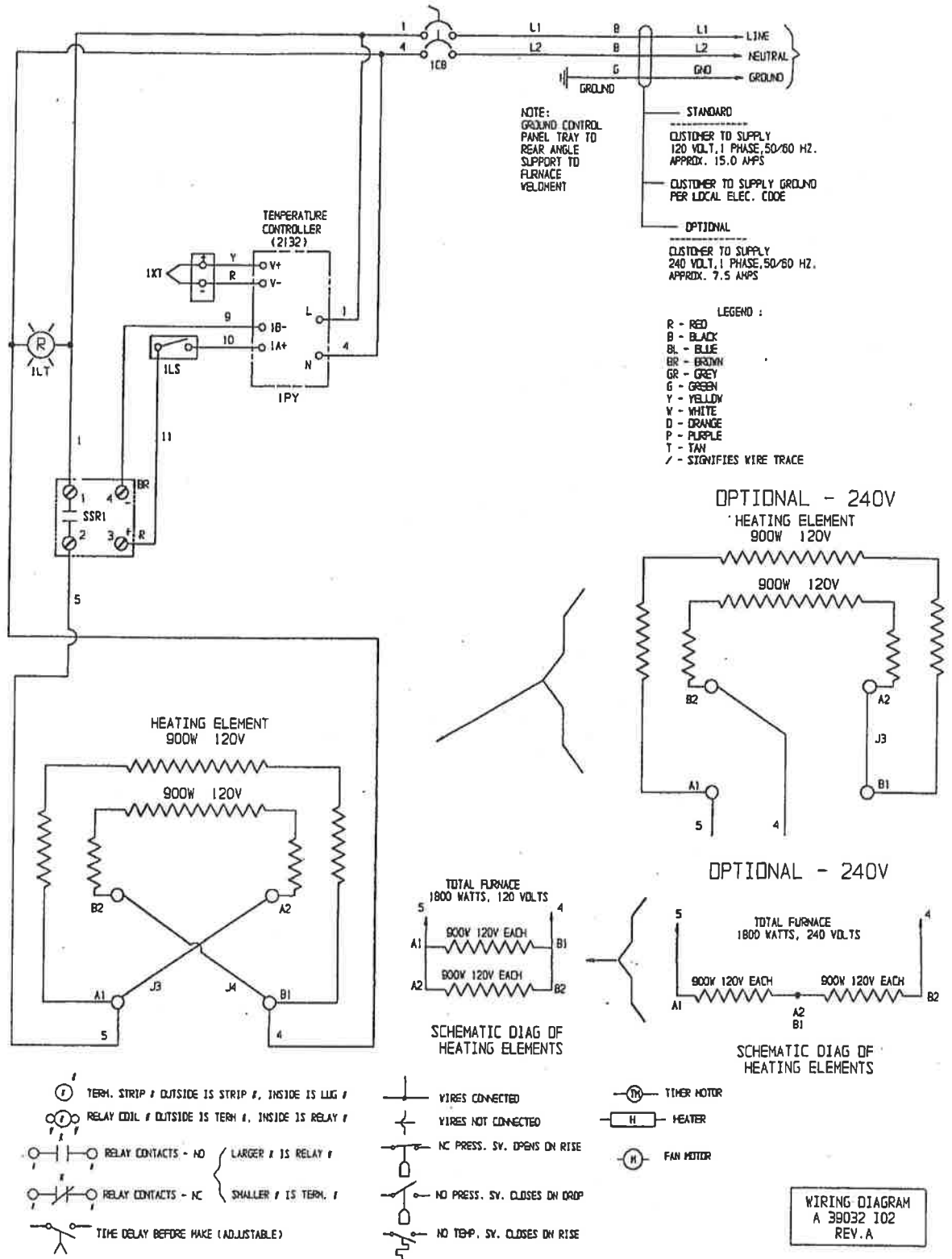

Figure 12. BF51666A and BF51666C



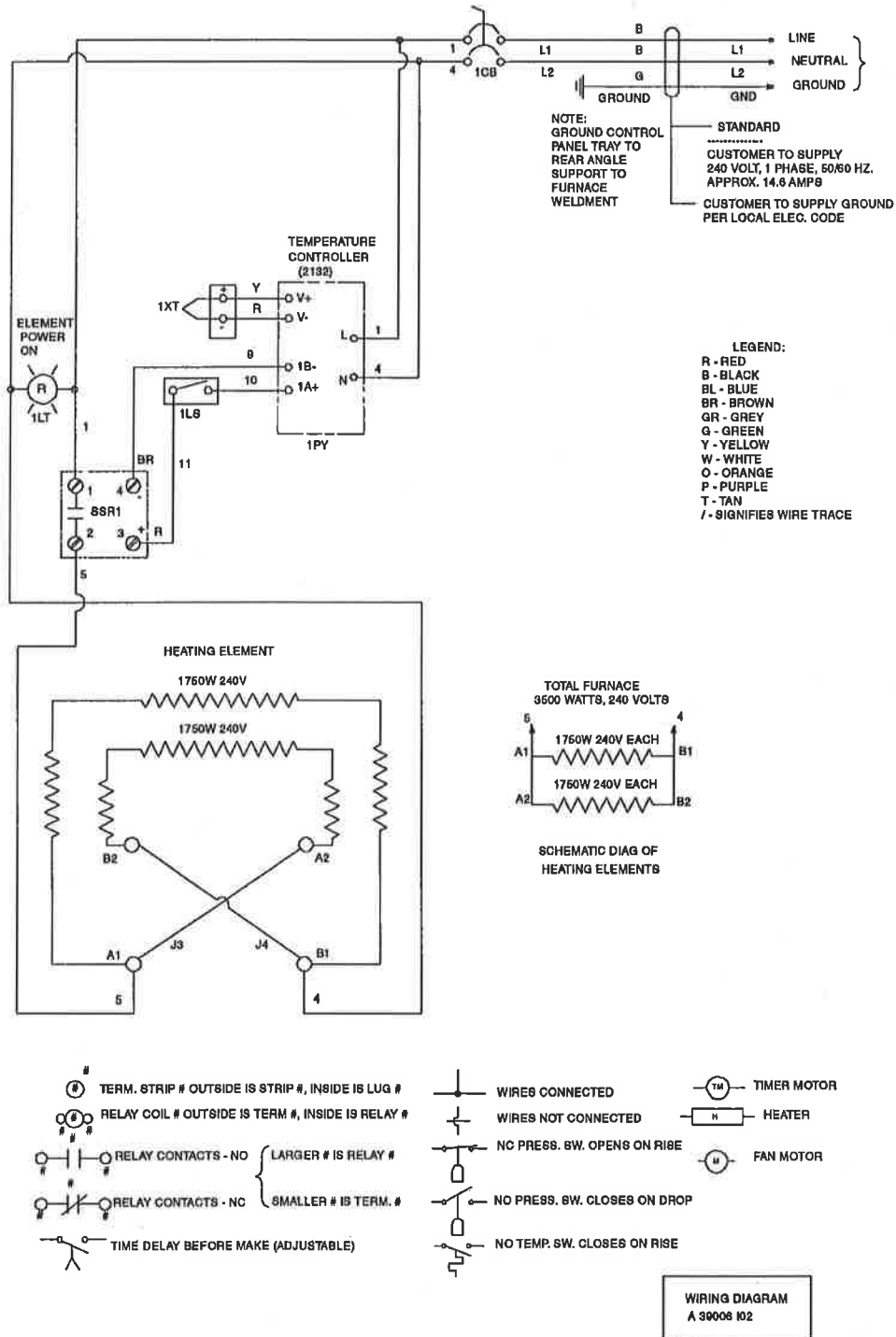

Figure 14. BF51694C

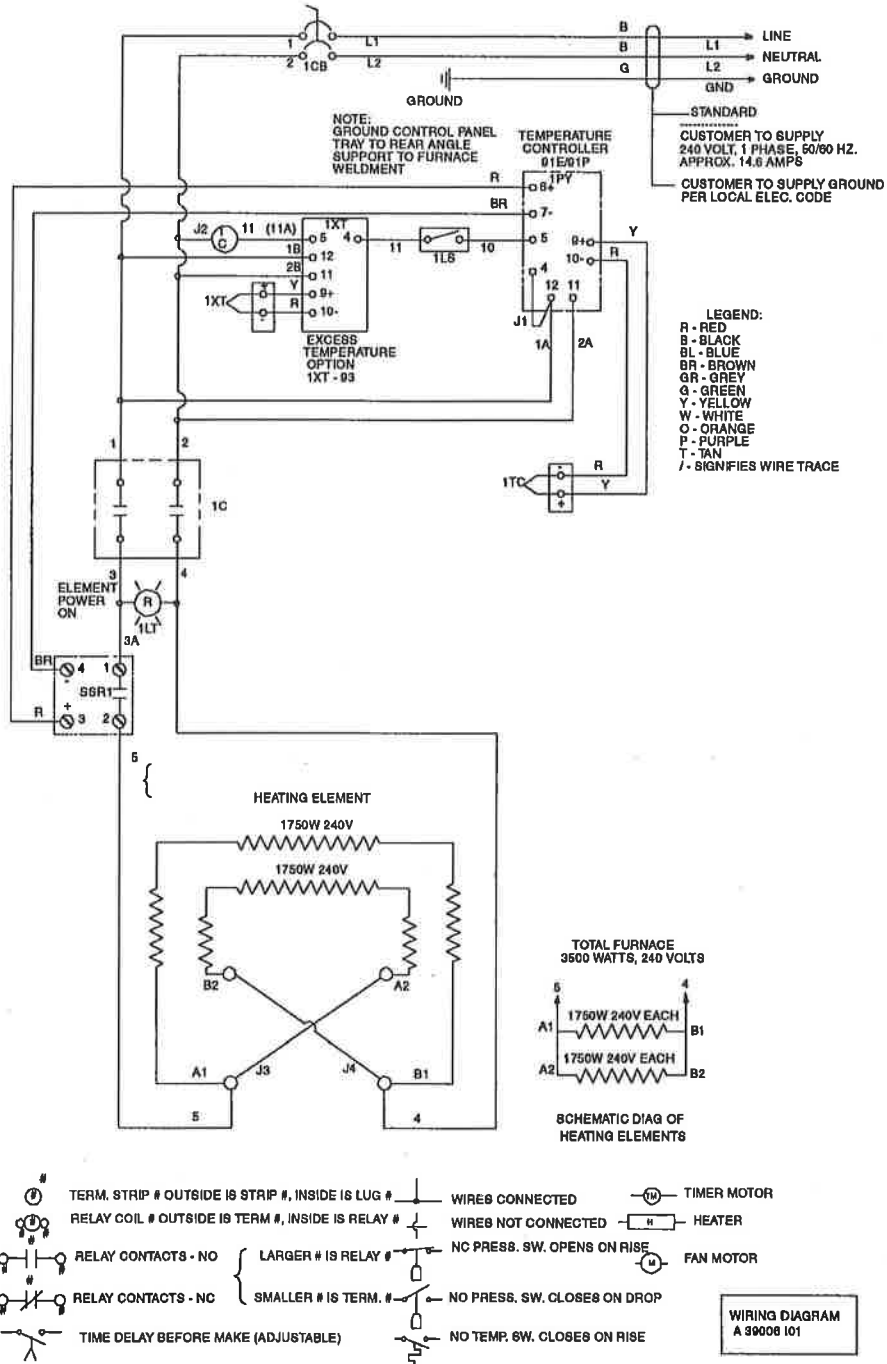

Figure 15. BF51794C



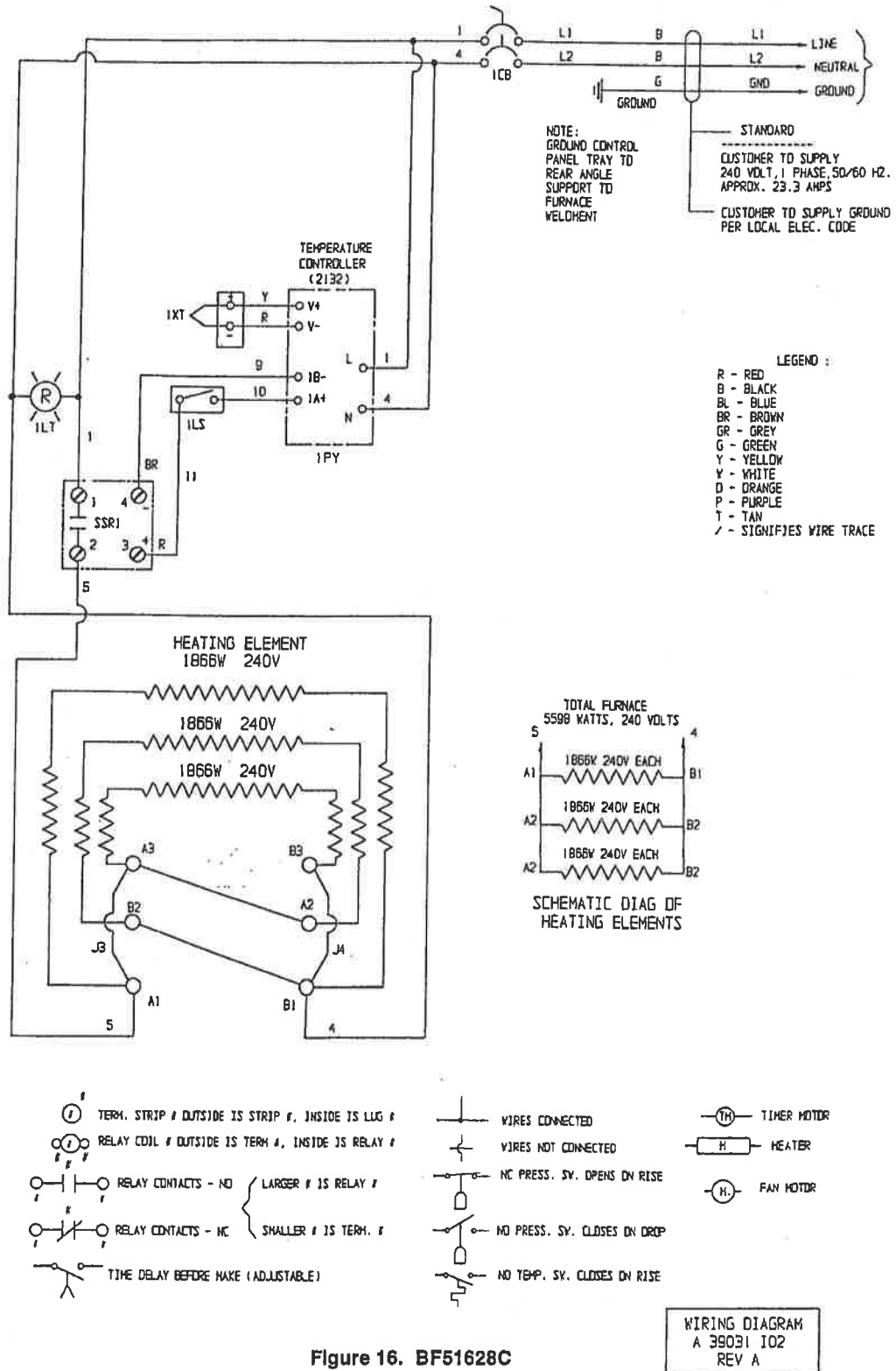

Figure 16. BF51628C

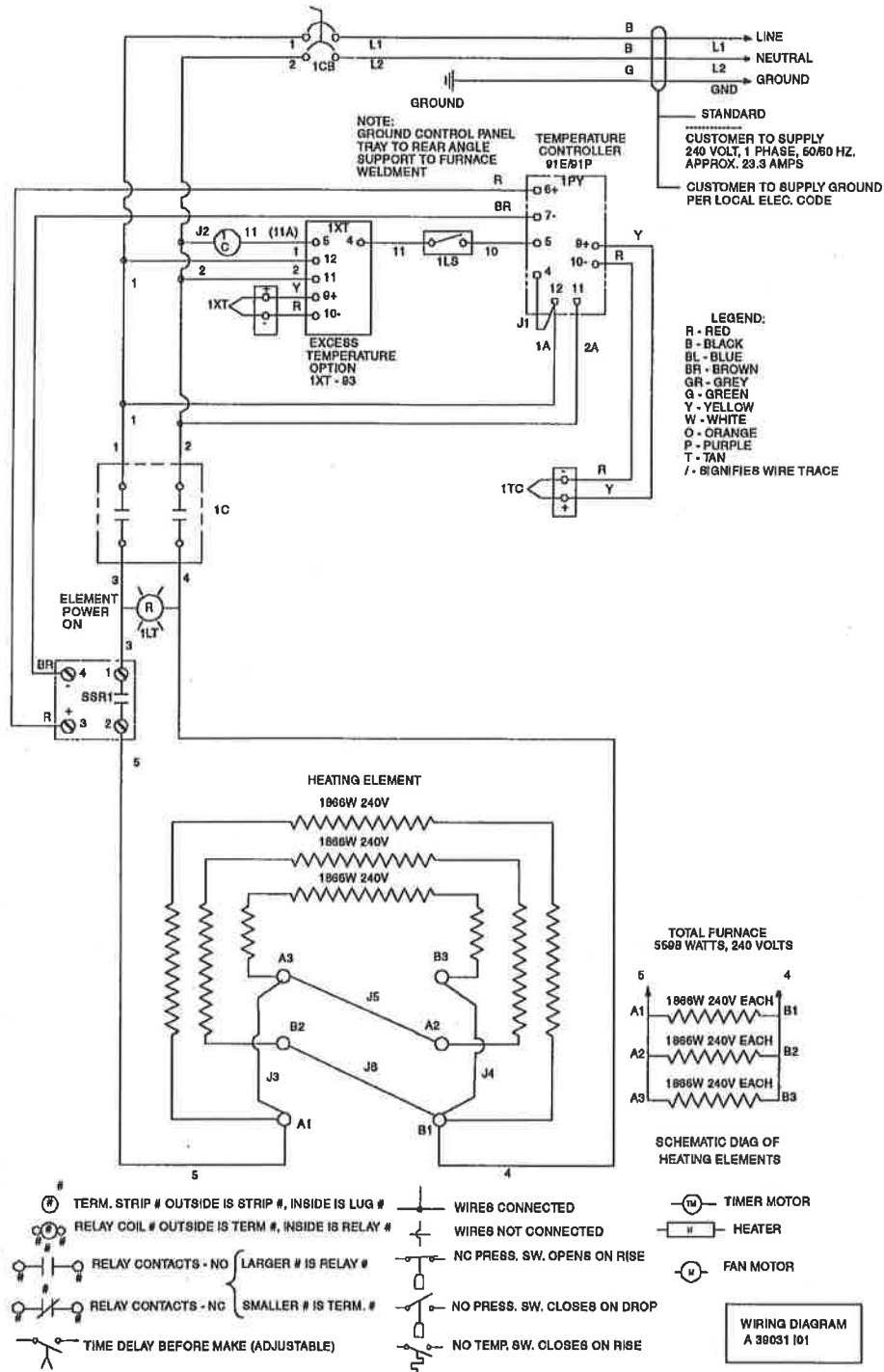

Figure 17. BF51728C

## 11 Warranty

### 11.1 Domestic Warranty (United States and Canada)

Lindberg/Blue M warrants this product to the owner for a period of twelve (12) months from date of shipment by Lindberg/Blue M. Under this warranty Lindberg/Blue M through its authorized Dealer or service organizations, will repair or at its option replace any part found to contain a manufacturing defect in material or workmanship, without charge to the owner, for a period of ninety (90) days, the labor, and a period of one (1) year, the parts, necessary to remedy any such defect. All components used in the manufacture of this product are covered by this warranty excluding heating elements and thermocouples.

This warranty is limited to products purchased and installed in the United States and Canada. It does not apply to damage caused from failure to properly install, operate, or maintain the product in accordance with the printed instructions provided. This warranty shall not apply to equipment or parts which have been subjected to negligence, accident, or damage by circumstances beyond Lindberg/Blue M's control or improper operation, application, maintenance, or storage.

To obtain prompt warranty service, contact the nearest Lindberg/Blue M authorized service center or Dealer. A listing of these companies will be provided upon request. Lindberg/Blue M's own shipping records showing date of shipment shall be conclusive in establishing the warranty period.

This warranty is in lieu of any other warranties, expressed or implied, including merchantability or fitness for a particular purpose. The owner agrees that Lindberg/Blue M's sole liability with respect to defective parts shall be as set forth in this warranty, and any claims for incidental or consequential damages are expressly excluded.

### 11.2 International Warranty (excluding Canada) 12 Months Parts Warranty

Lindberg/Blue M warrants this product to the original owner for a period of twelve (12) months from the date of shipment from the Lindberg/Blue M factory. Thermocouples and heating elements are excluded from this warranty. If any part is found to contain a manufacturing defect in material or workmanship Lindberg/Blue M will, at its option, repair or replace the part. Lindberg/Blue M assumes no responsibility for any labor expenses for service, removal, or reinstallation required to repair or replace the part, or for incidental repairs, and such costs are the responsibility of the Owner and his Dealer.

The warranty does not apply to damage caused by accidents, misuse, fire, flood, Acts of God or any other events beyond Lindberg/Blue M's control or to damage caused from failure to properly install, operate, or maintain the product in accordance with the printed instructions provided by Lindberg/Blue M. To obtain prompt warranty service, simply contact the Dealer from whom you purchased the product or the nearest Dealer handling Lindberg/Blue M products. Lindberg/Blue M's own shipping records showing date of shipment shall be conclusive in establishing the warranty period.

This warranty is in lieu of any other warranties, expressed or implied, including merchantability or fitness for a particular purpose. The owner agrees that its sole remedy and Lindberg/Blue M's sole liability with respect to defective parts or any other claim shall be as set forth in this warranty, and any claims for incidental, consequential or other damages are expressly excluded.

## 12 Moldatherm® Insulation Material Safety Data Sheet

Lindberg/Blue M, A Unit of General Signal

Moldatherm® Insulation Material Safety Data Sheet

**Manufacturer:** Lindberg/Blue M, A Unit of General Signal

**Address:** 275 Aiken Road  
Asheville NC 28804

**Telephone:** (704) 658-2711

**Revision Date:** November 6, 1992

Replaces MSDS dated: August 14, 1987

**Completed by:** Lindberg/Blue M Unit Environmental, Safety, and Health Department

I. PRODUCT IDENTIFICATION			
<b>Trade Name:</b>	Moldatherm II® Insulation (Also known as Moldatherm® Insulation)		
	Synonyms: Refractory Ceramic Fibers (RCFs); Ceramic Fiber; Man-Made Vitreous Fibers (MMVF); Mullite; High Alumina Ceramic Fiber		
<b>Chemical Family:</b>	Vitreous Aluminosilicate Fibers		
<b>Molecular Formula:</b>	Al <sub>2</sub> O <sub>3</sub> •SiO <sub>2</sub>		
II. PRODUCT COMPOSITION			
Component	CAS No.	Percent (%)	Exposure Limits (8 hr. TWA)
Aluminosilicate	NA – Mixture	79 to 99	1.0 fibers/cc**
Silica, amorphous	7631-86-9	1 to 21	10 mg/m <sup>3</sup> ACGIH/TLV 6 mg/m <sup>3</sup> OSHA/PEL
Remaining components not determined hazardous and/or other components present at less than 1.0% (0.1% for carcinogens).			
** NOTE: No OSHA or ACGIH exposure limits have been established for this material. The user is advised to follow the Lindberg/Blue M Recommended Exposure Limit (REL). (See Section VII. Personal Protective Equipment).			
Moldatherm® insulation will partially convert to cristobalite (CAS No. 14464-46-1), a form of crystalline silica, at operating temperatures at or above 1800°F. The rate and percentage of conversion to cristobalite is time and temperature dependent. (See Section X. Special Precautions/Supplemental Information.) Cristobalite has an OSHA permissible exposure limit (PEL) and ACGIH threshold limit value (TLV) of 0.05 mg/m <sup>3</sup> (respirable dust).			

NA = Not Applicable

III. PHYSICAL DATA					
Bolling Point:	NA	Vapor Pressure:	NA	Vapor Density:	NA
Evaporation Rate:	NA	% Volatile:	NA	Water Solubility (%):	Nil
Melting Point:	Greater than 3000°F	Odor/Physical Description:	White, odorless solid		
IV. FIRE AND EXPLOSION DATA					
Flash Point:	NA	Flammable Limits (LEL & UEL):	NA		
Unusual Fire or Explosion Hazards:	None	Extinguishing Media:	NA		
Fire Fighting Procedures:	Use extinguishing media suitable for surrounding fire.				
V. HEALTH HAZARDS					
<b>A. Health:</b>	WARNING! MAY BE IRRITATING TO SKIN, EYES, AND RESPIRATORY TRACT. MAY BE HARMFUL IF INHALED. POSSIBLE CANCER HAZARD BY INHALATION. Contains refractory ceramic fibers which MAY CAUSE CANCER BASED ON ANIMAL DATA. Risk of cancer depends on duration and level of exposure. (See Section X. for information concerning additional hazards after high temperature operation.)				
<b>B. Ingestion:</b>	Ingestion is unlikely. If ingested in sufficient quantity, may cause gastrointestinal disturbances. Symptoms may include irritation, nausea, vomiting, abdominal pain and diarrhea.				
<b>C. Skin:</b>	Slightly to moderate irritating. May cause irritation, inflammation, and rash.				
<b>D. Eye:</b>	Slightly to moderate irritating. Abrasive action may cause damage to the outer surface of the eye.				
<b>E. Inhalation:</b>	May irritate respiratory tract. Pre-existing medical conditions, especially chronic bronchial or lung disease may be aggravated by exposure.				
<b>F. Toxicity:</b>	Existing toxicology and epidemiology data are preliminary and the results presented below have not been validated by scientific review.				
<b>G. Epidemiology:</b>	<p>There are no known published reports of negative health affects of workers exposed to refractory ceramic fibers (RCFs). Studies of RCF production workers continues. Preliminary evidence, reportedly obtained from employees in RCF manufacturing facilities, indicates the following:</p> <ol style="list-style-type: none"> <li>1. There is no evidence on x-rays of any fibrotic lung disease of RCF manufacturing employees.</li> <li>2. There is no evidence of any lung disease among those employees exposed to RCF that never smoked.</li> <li>3. A statistical trend of slightly decreased pulmonary function was observed in the exposed population of workers based on the duration of RCF exposure. The statistic showing decreased pulmonary function was within the normal range and/or was insignificant.</li> </ol>				

NA = Not Applicable

	<p>Pleural plaques (thickening along the chest wall) have been observed in a small number of employees who had a long duration of employment. There are several occupational and non-occupational causes for pleural plaque. Plaques are not "pre-cancer" nor are they associated with any measurable effect on lung function.</p>
<b>H. Toxicology:</b>	<p>Several health effect studies of inhalation exposure of rats and hamsters are now reaching completion. In a lifetime nose-only inhalation study, rats exposed to a very high dose of 30 mg/m<sup>3</sup> (200 fibers/cc) developed progressive lung damage (interstitial fibrosis) and cancers of the lung and of the pleura (lining of the chest wall and lung). In contrast, hamsters similarly exposed developed interstitial fibrosis and pleural cancer, but no lung cancer. Cancer of the pleura is called mesothelioma.</p> <p>A multiple dose study (3, 9, 16 mg/m<sup>3</sup> or 25, 75, 150 fibers/cc, respectively) is currently ongoing in rats. After 24 months of exposure, only reversible cellular changes have been seen in the low dose group. At 9 mg/m<sup>3</sup> (75 fibers/cc), areas of lung fibrosis are barely discernible and at 16 mg/m<sup>3</sup> (150 fibers/cc) both lung and pleural fibrosis are present. At this time, no lung or pleural cancer has been seen in the multiple dose study. This information will be updated once the study is completed.</p> <p>In 1987, the International Agency for Research on Cancer (IARC) reviewed the carcinogenicity data on man-made vitreous fibers (including ceramic fiber, glasswool, rockwool, and slagwool). IARC classified ceramic fiber, fibrous glasswool and mineral wool (rockwool and slagwool) as possible human carcinogens (Group 2B).</p>
<b>VI. EMERGENCY AND FIRST AID PROCEDURES</b>	
<b>Ingestion:</b>	Drink extra water. Allow for natural gastrointestinal elimination. Get medical attention if gastrointestinal symptoms develop (see Section V.).
<b>Skin Contact:</b>	Remove contaminated clothing. Wash affected skin thoroughly with soap and water. Do not rub or scratch exposed skin. A skin cream or lotion used after washing may be helpful. Seek medical attention if irritation persists.
<b>Eye Contact:</b>	Immediately rinse eyes with water. Remove any contact lenses, and continue flushing eyes with running water for at least 15 minutes. Do not rub eyes. Hold eyelids apart to ensure rinsing of the entire surface of eyes and lids with water. Get immediate medical attention.
<b>Inhalation:</b>	Remove exposed person to fresh air. Seek medical attention if shortness of breath, cough, wheezing, or chest pain develop. If breathing is labored, administer oxygen until medical assistance can be rendered.
<b>VII. PERSONAL PROTECTIVE EQUIPMENT</b>	
<b>Eyes:</b>	Wear safety glasses or chemical goggles. Contact lenses should not be worn unless chemical goggles are also used and care is taken to not touch the eyes with contaminated body parts or materials.
<b>Skin:</b>	Wear gloves, hats and full body covering to prevent skin irritation as necessary (see Section X.).

NA = Not Applicable

<b>Respiratory Protection:</b>	<p>Use of properly designed and operating engineering controls is recommended and preferred over respiratory protection for controlling airborne dust and fiber concentrations.</p> <p>If exposures exceed our Recommended Exposure Limit (REL) of 1.0 fibers/cc of air (8 hour TWA) respiratory protection as outlined below must be used. Also, use respiratory protection if throat irritation is experienced. When airborne concentrations are unknown or exceed 0.5 f/cc, use of a half face respirator described below is recommended. Respiratory protection is necessary if the material has been exposed to temperatures at or above 1800°F. (See Section X.). Use only NIOSH/MSHA approved respirators.</p>
<b>Concentration (8 hour TWA)</b>	<b>Minimum Acceptable Respirator Type</b>
0 to 0.5 f/cc	Optional disposable dust respirator
0.5 f/cc to 5 f/cc or up to 10 times the OSHA PEL for cristobalite	Half face, air-purifying respirator equipped with high-efficiency particulate air (HEPA) filter cartridges
5 to 25 f/cc or up to 50 times the OSHA PEL for cristobalite (2.5 mg/m <sup>3</sup> )	Full face, air-purifying respirator with high-efficiency particulate air (HEPA) filter cartridges or powered air-purifying respirator (PAPR) equipped with HEPA filter cartridges
Greater than 25 f/cc or 50 times the OSHA PEL for cristobalite (2.5 mg/m <sup>3</sup> )	Full face, positive pressure supplied air respirator
As minimum protection, use half-mask air-purifying respirators equipped with HEPA filter cartridges if airborne fiber levels or cristobalite concentrations are not known.	
<b>PLEASE NOTE:</b>	
Employees must be given instruction, fit testing, medical evaluation, and training per 29 CFR 1910.134 and your company's written respirator program if respiratory protection is used. Appropriate respirator selection must be a part of the respirator program. The above respirator recommendations are general guidelines only and may not be appropriate for certain applications. Please consult with your safety or industrial hygiene staff or consultants.	
<b>VIII. REACTIVITY DATA</b>	
<b>Stability/Incompatibility:</b>	Stable under normal conditions of use. Soluble in hydrofluoric acid, phosphoric acid, and concentrated alkali.
<b>Hazardous Reactions/Decomposition Products:</b>	NONE
<b>IX. ENVIRONMENTAL AND REGULATORY INFORMATION</b>	
<b>Spill or Leak Procedure:</b>	Use vacuums equipped with HEPA filters to clean up spilled material. Wet sweeping is also acceptable.

NA = Not Applicable

<b>Waste Disposal:</b>	<p>This waste is not specifically listed as a hazardous waste under Federal regulations. However, it could be characteristically hazardous if it is considered toxic, corrosive, ignitable, or reactive according to Federal definitions (40 CFR 261). Additionally, it could be designated as hazardous or a special waste according to state regulations. This substance could also become a hazardous waste if it is mixed with or otherwise comes in contact with hazardous waste. Chemical additions, processing, or otherwise altering this material may make the waste management information presented in this MSDS incomplete, inaccurate, or otherwise inappropriate.</p> <p>The transportation, storage, treatment, and disposal of this waste material must be conducted in compliance with all applicable Federal, state, and local environmental regulations.</p>
<b>SARA Title III Information:</b>	<p>This material is designated a "delayed hazard" per the Superfund Amendments and Reauthorization Act (SARA) Section 311/312 (40 CFR 370).</p> <p>This product does not contain any toxic chemicals subject to the reporting requirements of SARA Section 313 (40 CFR 372).</p>
	<p>This product contains ceramic fibers which are on the State of California "Proposition 65" list (Safe Drinking Water and Toxic Enforcement Act of 1986).</p>
	<p>The Canadian Workplace Hazardous Materials Information System (WHMIS) category of "Other Toxic Effects" applies to this product.</p>
	<p>This product is not a DOT listed hazardous material. Use product name for bill of lading description.</p>
	<p>Some states have "special waste" regulations or other regulations which may apply to this product. Consult with your state environmental regulatory authorities.</p>
<b>X. SPECIAL PRECAUTIONS/SUPPLEMENTAL INFORMATION</b>	
<b>Handling/Storage:</b>	<p>Moldatherm® insulation should be handled with caution. Follow the personal protective equipment recommendations detailed in Section VII. Special precaution should be taken to avoid unnecessary cutting and tearing of the material to minimize generation of airborne dust.</p>
<b>Clothing:</b>	<p>Full body clothing is recommended to reduce the possibility of skin irritation. If possible, do not take unwashed work clothes home. Work clothes should be washed separately from other clothing. Rinse the washing machine thoroughly after laundering the work clothes. Inform your launderer of this cleaning procedure.</p>

NA = Not Applicable



<p><b>Cristobalite:</b></p>	<p>Product which has been in service at elevated temperatures (at or above 1800°F) over time may undergo partial conversion to cristobalite, a form of crystalline silica. This reaction occurs at the furnace lining hot face. As cristobalite is formed, Moldatherm® insulation becomes more friable; special caution must be taken to minimize generation of airborne dust. The amount of cristobalite formed will vary based on the operating temperature and length of service. (The IARC classification for crystalline silica is a group 2A carcinogen (probable human carcinogen). Cristobalite (crystalline silica) is also listed by NTP as a carcinogen).</p> <p><b>WARNING! DUST CAN CAUSE SEVERE RESPIRATORY DISEASE. DUST MAY BE IRRITATING TO SKIN, EYES, AND RESPIRATORY TRACT. SUSPECT CANCER HAZARD BY INHALATION. Cristobalite (crystalline silica) MAY CAUSE CANCER.</b></p> <p>The OSHA permissible exposure limit (PEL) and the ACGIH threshold limit value (TLV) for cristobalite is 0.05 mg/m<sup>3</sup> (respirable dust). Use NIOSH/MSHA approved respirators when airborne exposure limits may be exceeded. (See Section VII. table for respirator selection.)</p>
<p><b>Removal or Tearout of Moldatherm® Insulation:</b></p>	<p>Insulation surfaces should be lightly sprayed with water before removal to suppress airborne dust. Spray additional water as water evaporates during removal. A surfactant may aid the wetting process.</p> <p>After removal of the Moldatherm® insulation is complete, dust suppressing cleaning methods, such as wet sweeping or vacuuming should be used to clean the work area. If dry vacuuming is used, the vacuum must be equipped with a HEPA filter. Air blowing or dry sweeping should not be used. Dust suppressing components can be used to clean up light dust.</p> <p>Do not reuse product packaging because of possible product residue.</p>

**NOTICE:** The information presented here is based on data considered to be accurate as of the date of preparation of this Material Safety Data Sheet. However, no warranty or representation, express or implied, is made as to the accuracy or completeness of the foregoing data and safety information, nor is any authorization given or implied to practice any patented invention without a license. No responsibility can be assumed by vendor for any damage or injury resulting from abnormal use, from any failure to adhere to recommended practices, or from any hazards inherent in the nature of the product.

NA = Not Applicable

# WEEE Compliance

## Great Britain



**WEEE Compliance.** This products is required to comply with the European Union's Waste Electrical & Electronic Equipment (WEEE) Directive 2002/96EC. It is marked with the following symbol. Thermo Scientific has contracted with one or more recycling/disposal companies in each EU Member State, and this products should be disposed of or recycling through them. Further information on Thermo Scientific's compliance with these Directives, the recyclers in your country, and information on Thermo Scientific products which may assist the detection of substances subject to the RoHS Directive are available at [www.thermo.com/WEEERoHS](http://www.thermo.com/WEEERoHS)

## Deutschland



**WEEE Konformität.** Dieses Produkt muss die EU Waste Electrical & Electronic Equipment (WEEE) Richtlinie 2002/96EC erfüllen. Das Produkt ist durch folgendes Symbol gekennzeichnet. Thermo Scientific hat Vereinbarungen getroffen mit Verwertungs-/Entsorgungsanlagen in allen EU-Mitgliederstaaten und dieses Produkt muss durch diese Firmen wiederverwertet oder entsorgt werden. Mehr Informationen über die Einhaltung dieser Anweisungen durch Thermo Scientific, die Verwerter und Hinweise die Ihnen nützlich sein können, die Thermo Scientific Produkte zu identifizieren, die unter diese RoHS Anweisung fallen, finden Sie unter [www.thermo.com/WEEERoHS](http://www.thermo.com/WEEERoHS)

## Italia



**Conformità WEEE.** Questo prodotto deve rispondere alla direttiva dell'Unione Europea 2002/96EC in merito ai Rifiuti degli Apparecchi Elettrici ed Elettronici (WEEE). È marcato col seguente simbolo. Thermo Scientific ha stipulato contratti con una o diverse società di riciclaggio/smaltimento in ognuno degli Stati Membri Europei. Questo prodotto verrà smaltito o riciclato tramite queste medesime. Ulteriori informazioni sulla conformità di Thermo Scientific con queste Direttive, l'elenco delle ditte di riciclaggio nel Vostro paese e informazioni sui prodotti Thermo Scientific che possono essere utili alla rilevazione di sostanze soggette alla Direttiva RoHS sono disponibili sul sito [www.thermo.com/WEEERoHS](http://www.thermo.com/WEEERoHS)

## France



**Conformité WEEE.** Ce produit doit être conforme à la directive européenne (2002/96EC) des Déchets d'Equipements Electriques et Electroniques (DEEE). Il est marqué par le symbole suivant. Thermo Scientific s'est associé avec une ou plusieurs compagnies de recyclage dans chaque état membre de l'union européenne et ce produit devrait être collecté ou recyclé par celles-ci. Davantage d'informations sur la conformité de Thermo Scientific à ces directives, les recycleurs dans votre pays et les informations sur les produits Thermo Scientific qui peuvent aider le détection des substances sujettes à la directive RoHS sont disponibles sur [www.thermo.com/WEEERoHS](http://www.thermo.com/WEEERoHS)

For your future reference and when contacting the factory, please have the following information readily available:

Model Number: \_\_\_\_\_

Serial Number: \_\_\_\_\_

The above information can be found on the dataplate attached to the equipment. If available, please provide the date purchased, the source of purchase (Lindberg/Blue M or specific agent/rep organization), and purchase order number.

---

**IF YOU NEED ASSISTANCE:**

**LINDBERG/BLUE M SALES DIVISION**

Phone: 828/658-2711  
800/252-7100

FAX: 828/645-3368

**LABORATORY PARTS and SERVICE**

Phone: 828/658-2891  
800/438-4851

FAX: 828/658-2576

**TECHNICAL SUPPORT**

Phone: 800/438-4851

**LINDBERG/BLUE M**

275 Aiken Road  
Asheville, NC 28804  
U.S.A.