



**Anton Paar**

Measure  
what is measurable  
and make measurable  
that which is not.

Galileo Galilei (1564-1642)

Instruction Manual and Safety Information

# **MCR 702e Space MultiDrive**

Modular Compact Rheometer

(Original Instruction)



## Disclaimer

This document may contain errors and omissions. If you discover any such errors or if you would like to see more information in this document, please contact us at our address below. Anton Paar assumes no liability for any errors or omissions in this document.

## Changes, copyright, trademarks etc.

This document and its contents may be changed or amended by Anton Paar at any time without prior notice.

All rights reserved (including translation). This document, or any part of it, may not be reproduced, changed, copied, or distributed by means of electronic systems in any form (print, photocopy, microfilm or any other process) without prior written permission by Anton Paar GmbH.

Trademarks, registered trademarks, trade names, etc. may be used in this document without being marked as such. They are the property of their respective owner.

## Further information

Published and printed by Anton Paar GmbH, Austria

Copyright © 2022 Anton Paar GmbH, Graz, Austria

Address of the instrument producer:

Anton Paar GmbH  
Anton-Paar-Str. 20  
A-8054 Graz / Austria – Europe

Tel: +43 (0) 316 257-0

Fax: +43 (0) 316 257-257

E-Mail: [info@anton-paar.com](mailto:info@anton-paar.com)

Web: [www.anton-paar.com](http://www.anton-paar.com)

Date: September 2022

Document number: C92IB037EN-E

---

# Instruction Manual and Safety Information

## MCR 702e Space MultiDrive

Modular Compact Rheometer

(Original Instruction)

# Contents

<b>1 About the Instruction Manual .....</b>	<b>5</b>
<b>2 Safety Instructions.....</b>	<b>6</b>
2.1 General Safety Instructions.....	6
2.2 Special Safety Instructions.....	7
2.3 Warning Signs on the Instrument.....	7
2.4 Intended Use of the Instrument.....	8
2.5 Remaining Risks .....	8
<b>3 MCR 702e Space MultiDrive - An Overview .....</b>	<b>9</b>
3.1 Overview of the Rear Connections .....	10
<b>4 Checking the Supplied Parts .....</b>	<b>12</b>
4.1 MCR Modular Compact Rheometer.....	12
4.2 Accessory Kit for the MCR 702e Space MultiDrive.....	13
<b>5 Preparing the Instrument .....</b>	<b>16</b>
5.1 Installation Requirements .....	16
5.2 Connecting the MCR 702e Space MultiDrive to the Air Supply .....	16
5.3 Mounting the Hose Holder .....	17
5.4 Connecting the Electronics Box to Power.....	17
5.5 Connecting the Measuring Unit to the Electronics Box.....	17
5.6 Removing the Transport Protection with Reference Movement of the Measuring Head .....	17
5.7 Leveling the Instrument.....	18
5.8 Connecting a Fluid Circulator.....	18
5.8.1 Fluid Circulator without Lower Measuring Drive .....	19
5.8.2 Fluid Circulator with Lower Measuring Drive .....	19
5.9 Connecting to the PC.....	19
5.9.1 Ethernet .....	20
5.9.2 USB .....	20
<b>6 Operating the MCR .....</b>	<b>21</b>
6.1 Switching on the Instrument.....	21
6.2 The MCR Electronics Box Display .....	21
6.3 The MCR Operating Panel.....	22
6.4 MCR Menu.....	23
6.5 MCR Maintenance Indicator .....	24
<b>7 Upkeep and Cleaning .....</b>	<b>25</b>
7.1 Cleaning and Drying the Measuring Cells.....	25
7.2 Wetted Parts .....	25
7.3 Storing and Transporting the Instrument .....	26
7.4 Packing the Instrument for Transport.....	26
<b>8 Maintenance and Repair.....</b>	<b>29</b>
8.1 Maintenance Performed by an Authorized Anton Paar Service Engineer .....	29
8.2 Repair Performed by an Authorized Anton Paar Representative .....	29
<b>Appendix A: Technical Data .....</b>	<b>30</b>
Appendix A.1: Technical Data MCR 702e Space MultiDrive .....	30
Appendix A.2: Operation in a Glove-box.....	32
Appendix A.3: Pin Assignments.....	32
<b>Appendix B: Declaration of Conformity.....</b>	<b>35</b>

# 1 About the Instruction Manual

This instruction manual informs you about the installation and the safe handling and use of the MCR 702e Space MultiDrive. Pay special attention to the safety instructions and warnings in the manual and on the product.

The instruction manual is a part of the product. Keep this instruction manual for the entire life span of the product and make sure it is easily accessible to all people involved with the product. If you receive any additions or revisions to this instruction manual from Anton Paar GmbH, these have to be treated as part of the instruction manual.

## Appendix to the Manual on USB storage

The instruction manual at hand describes the most important features and functions. Find further information about the instrument and especially about the installation of the RheoCompass software on the enclosed USB storage device.

## Conventions for safety messages

The following conventions for safety messages are used in this instruction manual:



### DANGER

#### Description of risk

Danger indicates a hazardous situation which, if not avoided, **will** result in death or serious injury.



### WARNING

#### Description of risk

Warning indicates a hazardous situation which, if not avoided, **could** result in death or serious injury.



### CAUTION

#### Description of risk

Caution indicates a hazardous situation which, if not avoided, could result in minor or moderate injury.

### NOTICE

#### Description of risk

Notice indicates a situation which, if not avoided, could result in damage to property.



### CAUTION

#### Hot surface

This symbol calls attention to the fact that the respective **surface can get very hot**. Do not touch this surface without adequate protective measures.



### CAUTION

#### Danger of hand injuries

In areas marked with this sign there is the possibility of hand or finger injuries through moving parts. Keep a safe distance as long as parts of the instrument are still in motion.



#### Wear protective gloves

Wear protective gloves when handling the MCR.



#### Wear safety goggles

Wear safety goggles when handling the MCR.

**TIP:** *Tips give helpful additional information about the situation at hand.*

**Information:** *Information gives extra information about the situation at hand.*

# 2 Safety Instructions

- Read this instruction manual before using the MCR.
- Follow all tips and instructions contained in this instruction manual to ensure the correct use and safe functioning of the MCR.
- Read and follow the safety instructions in the documentation of any accessory that is used together with the MCR.
- All personnel involved in the operation and/or maintenance of the equipment must be properly instructed in its use.
- This manual contains important information on operating and handling the instrument. You are therefore required to keep the manual with the instrument, especially when transferring the instrument to other persons.
- Make sure all operators are trained to use the instrument safely and correctly before starting any applicable operations.
- In case of damage or malfunction, do not continue operating the MCR. Do not operate the instrument under conditions which could result in damage to goods and/or injuries and loss of life.
- Make sure the MCR is chemically resistant to the samples and cleaning agents you want to use.
- The MCR must not be operated in any other atmosphere than defined in appendix A.
- The MCR must not be operated at an pressure considerably below usual ambient air pressure.

## 2.1 General Safety Instructions

### Liability

- This instruction manual does not claim to address all safety issues associated with the use of the instrument and samples. It is your responsibility to establish health and safety practices and determine the applicability of regulatory limitations.
- Anton Paar GmbH only warrants the proper functioning of the MCR if no adjustments have been made to the mechanics, electronics, and software.
- Only use the MCR for the purpose described in this instruction manual. Anton Paar GmbH is not liable for damages caused by incorrect use of the MCR.

### Installation and use

- The MCR is **not** an explosion-proof instrument and therefore must not be operated in areas with risk of explosion.
- The installation procedure should only be carried out by authorized persons who are familiar with the installation instructions.
- Do not use any accessories or spare parts other than those supplied or approved by Anton Paar GmbH.

### Maintenance and service

- The results delivered by the MCR not only depend on the correct functioning of the instrument, but also on various other factors. We therefore recommend you have the results checked (e.g. plausibility tested) by skilled personnel before consequential actions are taken based on the results.
- Service and repair procedures may only be carried out by authorized personnel or by Anton Paar GmbH.

### Disposal

- Concerning the disposal of the MCR, observe the legal requirements in your country.

### Return shipment

- For repairs contact your Anton Paar representative and send the MCR in its original packaging. Send the lower measuring drive in its own transport case. Find the contact details on the Anton Paar home page ([www.anton-paar.com](http://www.anton-paar.com)).

### Precautions for highly flammable samples and cleaning agents

- Observe and adhere to your national safety regulations for handling the measured samples (e.g. use of safety goggles, gloves, respiratory protection etc.).
- Only store the minimum required amount of sample, cleaning agents and other flammable materials near the MCR.

- Do not spill sample/cleaning agents or leave their containers uncovered. Immediately remove spilled sample/cleaning agents.
- Make sure that the setup location is sufficiently ventilated. The environment of the MCR has to be kept free of flammable gases and vapors.
- Connect the MCR to the mains via a safety switch located at a safe distance from the instrument. In an emergency, turn off the power using this switch instead of the power switch on the MCR. Make sure this safety switch is and stays accessible at all times.
- Supply a fire extinguisher.
- During operation the MCR must be under constant qualified supervision.

## 2.2 Special Safety Instructions

- Do not use the MCR to measure fluids of the IIC group according to EN 60079-14, such as e.g. carbon disulfide or acetylene.
- Do not operate the MCR or move and touch the coupling unless you have connected a suitable compressed air supply with correct pressure.
- Parts of the instrument and its accessories as well as the measuring system and the sample may become very hot or cold during operation. Touching these areas may cause severe burns. Do not touch any surface without adequate protective measures at these temperatures.
- Heated or cooled areas may take considerable time to reach room temperature. Allow these areas to cool down / warm up to room temperature or wear adequate protection before touching them.
- Some materials may evaporate during measurement, especially at high temperatures. Ensure adequate protection from hazardous gases. The measuring temperature should be set in such a way that no explosive substances can develop. Ensure adequate handling routines, such as protective clothing and good ventilation, when you are measuring potentially hazardous or volatile samples. Wear protective gloves and goggles when handling the MCR.
- Stay clear of the MCR head when it is moving. Do not place your hands or other parts of your body between the MCR head and the plate or hood. Keep a safe distance as long as parts of the instrument are still in motion.

- Always wear adequate protective equipment (goggles, gloves) when operating the MCR.

## 2.3 Warning Signs on the Instrument

There are several warning symbols on the MCR (Fig. 1). Three are on the front of the main girder, two at the bottom and one at the top.

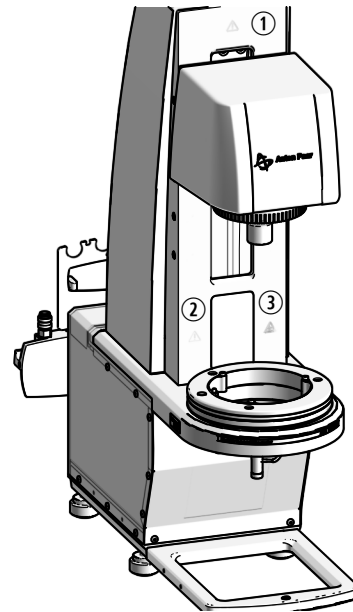

- 1 CAUTION - General risks
- 2 CAUTION - General risks
- 3 CAUTION - Moving parts

Fig. 1: Position of warning symbols on the instrument.



### CAUTION

#### General risk

There is a general risk in the area marked with this symbol. Carefully read the documentation and observe all safety notes.



### CAUTION

#### Moving parts

There is a risk of body parts being pinched in the area marked with this symbol. Keep clear of this area while parts of the instrument are moving.

### NOTICE

It is imperative that the warning symbols remain clearly legible.

### 2.4 Intended Use of the Instrument

The MCR is intended for the measurement of the rheological properties of a wide range of different samples.

The MCR may only be used in the way it is described in this manual and other documentation provided by Anton Paar for this instrument and for its accessories.

### 2.5 Remaining Risks



#### CAUTION

##### **Hot surface**

Parts of the instrument may become very hot during operation.

Do not touch these parts of the instrument without adequate protective measures or let it cool down before handling.



#### CAUTION

##### **Moving parts**

There is a risk of body parts being pinched by the moving measuring head.

Keep clear of the measuring head while it is moving.



#### CAUTION

##### **Heavy object**

The MCR is heavy (up to 60 kg with accessories), therefore adequate lifting by two persons is required to prevent injuries and instrument damage. Never lift the MCR by its head.

There are recessed grips at the bottom of the instrument (Fig. 2, ⑥), which should always be used to lift the MCR.



#### CAUTION

##### **Top-heavy object**

When working without the removable ground plate (Fig. 2, ⑨), the MCR 702e Space MultiDrive is top-heavy and tends to tilt forward. Do not operate the instrument before fixing it properly. Disregarding this warning could result in personal injury and/or equipment damage.

Some of the accessories and measuring systems may represent an additional risk; e.g.:

- The SCF (solid cylindrical fixture) and SRF (solid rectangle fixture) measuring systems allow mounting sharp objects.
- The BIC (bicone) measuring systems have a very sharp edge that additionally may be rotating at a high speed (up to 3000 rpm).
- The CC (concentric cylinder) or DG (double gap) measuring systems may expose a shearing hazard between the cylinder and the cup when the cylinder is immersed into the cup.
- The surroundings and objects near to heating devices may also become hot.



#### CAUTION

##### **Moving parts**

Moving parts may generally expose a risk of getting injured.

Keep clear of moving parts.

##### **NOTICE**

Observe the safety information in the documentation of the accessories and measuring systems.



## 3 MCR 702e Space MultiDrive - An Overview

The **Modular Compact Rheometer** series incorporates an EC-motor and is designed for a wide range of measurement tasks. Temperature control and sample specific accessories adapt the instrument to the desired application. The rheometer software together with the Toolmaster - the automatic recognition and configuration system - are the user friendly interface.

The MCR 702e Space MultiDrive (With Exposed Support Plate) is composed of a measuring unit and an electronics box.

**Information:** *In order to install certain accessories (e.g. a confocal microscope) the removable ground plate (Fig. 2, ⑨) might be dismantled.*

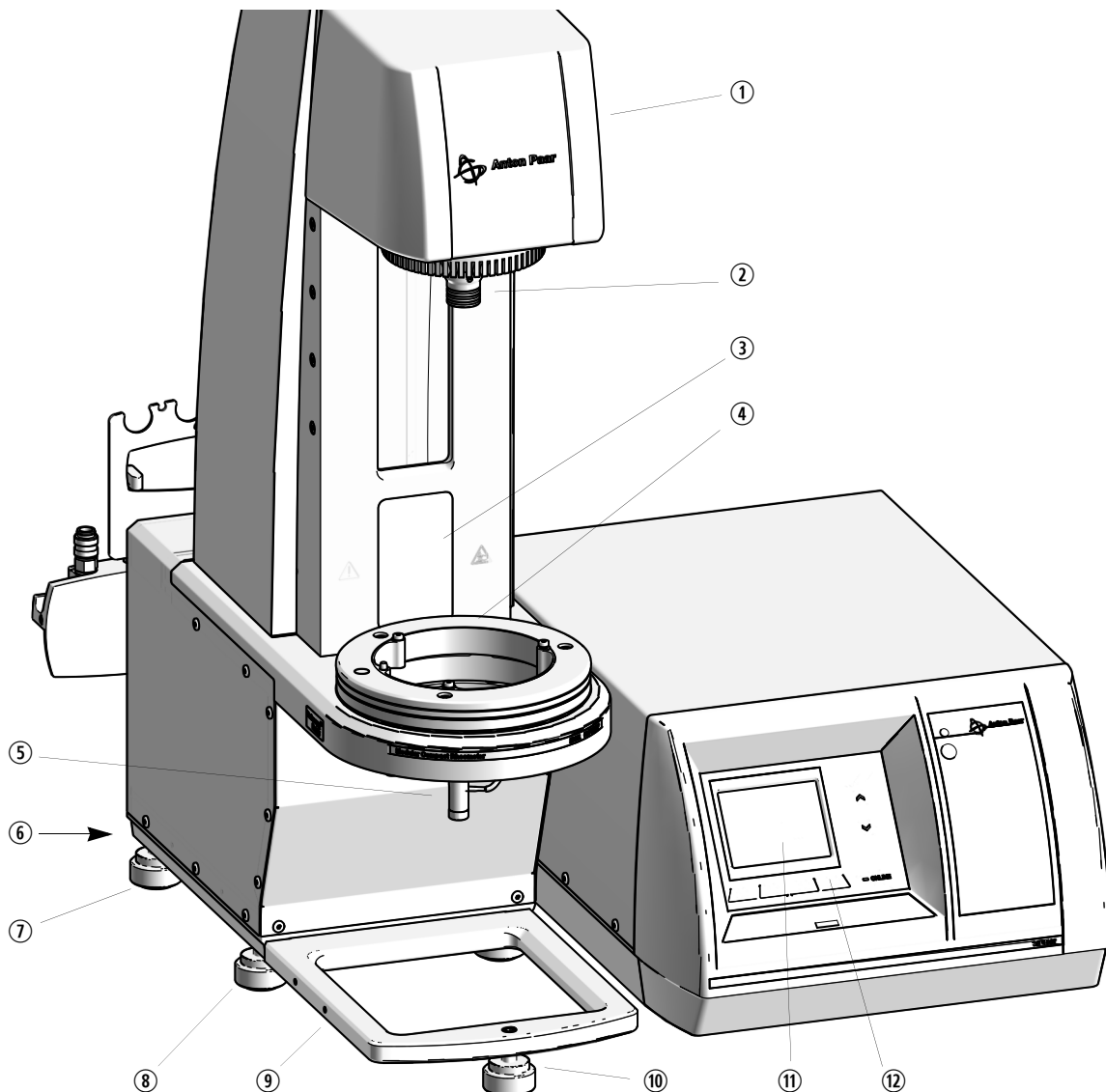

- |  |                                 |
|--|---------------------------------|
| 1 MCR measuring head   | 7 Rear adjustable feet (2x)     |
| 2 MCR coupling for upper measuring system  | 8 Front adjustable feet (2x)    |
| 3 Trimming mirror  | 9 Removable ground plate        |
| 4 Flange ring (Temperature device holder)  | 10 Ground plate adjustable foot |
| 5 Piezo actuator (one of three; removed when operated in Argon atmosphere, see appendix A.2) | 11 Color display                |
| 6 Recessed grip  | 12 Softkeys                     |

Fig. 2: Front overview of the MCR 702e Space MultiDrive

### 3.1 Overview of the Rear Connections

You will find all necessary parts to connect the MCR and to connect all accessories to it in the accessory kit.



**WARNING**

**Electric shock hazard**  
Parts behind the MCR electronics box carry hazardous voltage. Do not open the instrument, there are no user-serviceable parts inside. Do not operate the instrument when electronic units or covers are missing. All screws must be tight.

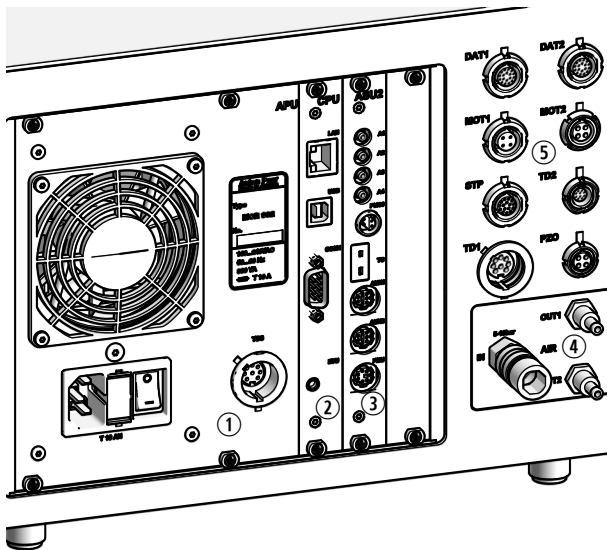

- 1 APU (analog power unit)
- 2 CPU (central processing unit)
- 3 ASU (analog sensor unit)
- 4 AIR connectors
- 5 Measuring Unit Connection

Fig. 3: Connections on the rear panel of the electronics box

**APU (analog power unit):**

- TD3:** temperature device connection; apply clip-on ferrites to external heating cables
- Main power switch
- Fuse:** T10AH
- Main power connection including protective earth

**CPU (central processing unit):**

- LAN:** Ethernet interface for network communication
- USB:** interface for direct communication with a computer
- COM1:** serial port for controlling external devices
- EVU:** connector for evaporation unit

**ASU (analog sensor unit):**

- A1 - A4:** 4 analog outputs
- Pt100:** interface for temperature reading with a Pt100 sensor
- TC:** interface for temperature reading with a thermocouple
- AUX1:** auxiliary connector with relays output (+24 V) and input for reading external devices
- AUX2:** auxiliary connector with relays output (+24 V) and input for reading external devices  
See specifications in appendix A.3.
- FMU:** connector for magnetic valve of the flow meter unit

**AIR:**

- IN:** Connection to air supply; pressure 5 to 10 bar
- OUT1:** air connection to upper motor
- OUT2:** air connection to lower motor (MultiDrive mode only)

**Measuring Unit Connection:**

- DAT1:** Motor control connection to the MCR Measuring unit
- DAT2:** Motor control connection to the Lower Measuring Drive
- MOT1:** Electrical connection to the MCR Measuring unit
- MOT2:** Electrical connection to the Lower Measuring Drive
- STP:** Stepper motor connection
- TD1:** Temperature device connection
- TD2:** Connector for TruGap and lower shafts
- PZO:** IsoLign Piezo flange connection

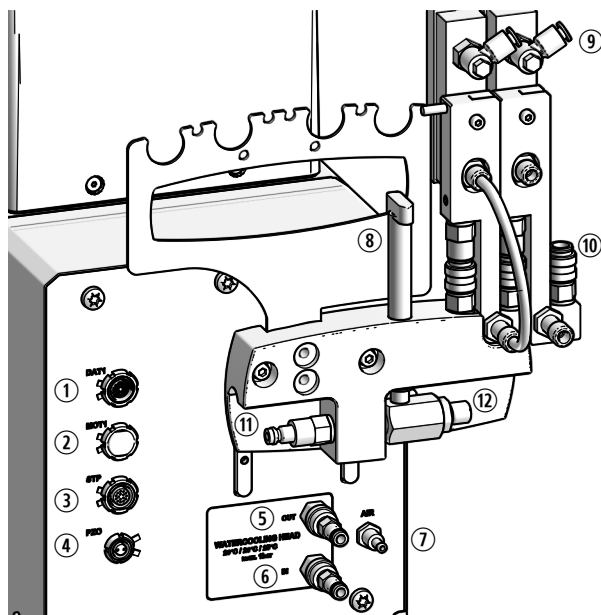

- 1 DAT1: Motor control connection to the electronics box
- 2 MOT1: Electrical connection to the electronics box
- 3 STP: Stepper motor connection to the electronics box
- 4 PZO: IsoLign Piezo flange connection to the electronics box
- 5 Water cooling upper motor OUT
- 6 Water cooling upper motor IN
- 7 AIR: connect to electronics box
- 8 Stop-cock for switching the air on and off
- 9 Flow Meter Unit (FMU) connectors
- 10 Connector for an additional FMU
- 11 Compressed air distributor OUT: connect the magnetic valve
- 12 Compressed air distributor IN: connect the air supply (max. 6 bar)

Fig. 4: Connections on the rear panel of the MCR 702e Space MultiDrive measuring unit.

#### NOTICE

The water-cooling of the measuring drive to stabilize the temperature of the measuring head has to be connected to a fluid circulator, which is also available from Anton Paar GmbH.

The recommended temperatures are 20 °C, 23 °C or 25 °C and should be as near to room temperature as possible.

The temperature must be constant and **must not** exceed the range between 15 °C and 35 °C at a maximum pressure of 1 bar.

# 4 Checking the Supplied Parts

The MCR has been tested and packed carefully before shipment. However, damage may occur during transport.

1. Keep the packaging material (box, foam piece, transport protection) for possible returns and further questions from the transport or insurance company.
2. Check the delivery for completeness by comparing the supplied parts to those noted in the packing list.
3. If a part is missing, contact your Anton Paar representative.
4. If a part is damaged, contact the transport company and your Anton Paar representative.

The following tables list all supplied parts. Every instrument is delivered as a unit and the delivery contains all parts according to your order.

## 4.1 MCR Modular Compact Rheometer



### CAUTION

#### Heavy object

The MCR is heavy (up to 60 kg with accessories), therefore adequate lifting by two persons is required to prevent injuries and instrument damage. Never lift the MCR by its head. There are recessed grips at the bottom of the instrument (Fig. 2, ⑥), which should always be used to lift the MCR.

Table 1: Supplied parts



Symbol	Pcs.	Article Description	p/n
	1	<b>MCR 702e Space MultiDrive Measuring Unit</b> Modular Compact Rheometer with Exposed Support Plate, Measuring unit	241357
	1	<b>MCR 702e Space MultiDrive Electronics Box</b>	
	1	<b>MCR 702e Space MultiDrive Accessory Kit</b> complete with all necessary parts and tools for the MCR, consists of 3 boxes	

Table 1: Supplied parts

Symbol	Pcs.	Article Description	p/n
	1	<b>Instruction manual</b>	(241357)
	1	<b>USB Storage Device</b> with further information	

## 4.2 Accessory Kit for the MCR 702e Space MultiDrive

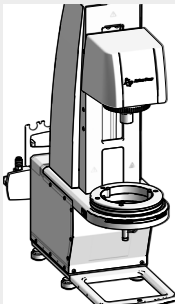
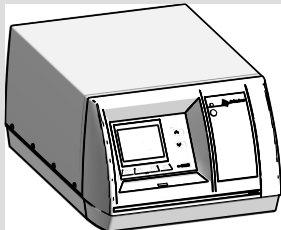
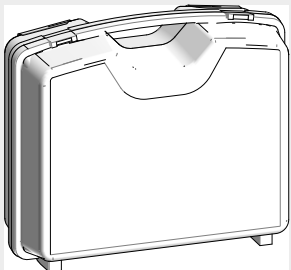

The **accessory kit** contains all parts and tools necessary for installing the MCR. It consists of a tool box and a box with hoses and cables.

Table 2: Contents of the cable and hose box

Symbol	Pcs.	Article Description	p/n
	1x2 m	Ethernet cable for network connection RJ45G SFTP CAT5e	18470
	1x2 m	USB connection cable A/Plug - B/Plug	94228
	2.5 m	Power cable (3x1.0 mm <sup>2</sup> , 10 A), suitable for destination country - CEE - UK - USA - China - CH - Thailand - Brazil	52112 61865 52656 27011 93408 79730 130117
	2x3 m	Air hose connection to the air filter unit including: Air hose 4x6 polyurethane Chainflex black, 2x fitting NW7.2-6x4 1x self-locking fitting NW5-6x4 red	26936 26933 26935

## 4 Checking the Supplied Parts

**Table 2: Contents of the cable and hose box**

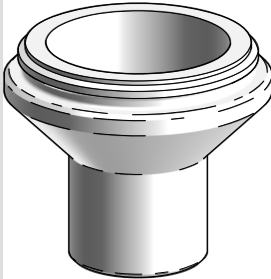
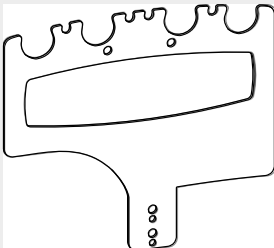
Symbol	Pcs.	Article Description	p/n
	4x2 m	Measuring drive - circulator including: Thermostat hose 7.9x15.9mm, NBR/CR black, 2x self-locking coupling NW5-9mm 2x self-locking coupling NW5-9mm blue 12x hose clamps 4x marking "Watercooling Head" 1x short adapter hose blue to blank	94166 74948 14385 94168
	1	Flow indicator 6 - 11 mm	93035
	1	Water circuit connection hose	
	1	Protection tube	2834
	1	Hose holder	91322

**Table 3: Content of the tool box**



Symbol	Pcs.	Article Description	p/n
	1	Aluminum water level L=150 mm, sensitivity=0.6 mm/m	17205
	4	Allen wrench 2.0 mm Allen wrench 4x100 mm	222422 300494
	1	Viscoelastic reference, PSTD1000VE, 50 ml	9696

Table 3: Content of the tool box

Symbol	Pcs.	Article Description	p/n
	1	Double spatula 18/10 steel, 150x9mm	98595
	3	Knurled screw M3x6, MCR	99678
		Mounting material for the hose holder 2x M5x20 screw 2x M5 washer	

Table 4: Contents of the connector cable box

Symbol	Pcs.	Article Description	p/n
	1	Control cable (DAT) for measuring unit	131897
	1	Power cable (MOT) for measuring unit	131898
	1	Isolign Piezo flange (PZO) control cable	173044
	1	Control cable for stepper motor (STP)	173045
	1	Control cable (DAT) for lower measuring drive	173046
	1	Power cable (MOT) for lower measuring drive	173047
	2	Air hoses	
	1	Replacement standard flange without piezo elements <sup>a</sup>	

*a The flange may only be replaced by Anton Paar certified service technicians.*

# 5 Preparing the Instrument

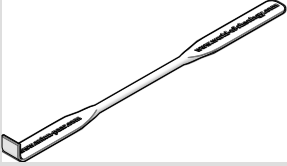
## 5.1 Installation Requirements



### CAUTION

#### **Moving parts.**

There is a risk of body parts being jammed between the upwards moving measuring head and other objects above the MCR. Maintain a clearance of at least 50 cm above the MCR.



### CAUTION

#### **Heavy object**

The MCR is heavy (up to 60 kg with accessories), therefore adequate lifting by two persons is required to prevent injuries and instrument damage. Never lift the MCR by its head. There are recessed grips at the bottom of the instrument (Fig. 2, ⑥), which should always be used to lift the MCR.



### CAUTION

#### **Top-heavy object**

When working without the removable ground plate (Fig. 2, ⑨), the MCR 702e Space MultiDrive is top-heavy and tends to tilt forward. Do not operate the instrument before fixing it properly. Disregarding this warning could result in personal injury and/or equipment damage.

The setup location and surroundings should meet the requirements of a typical laboratory (see below and appendix A).

Allow the equipment to reach ambient temperature before installation. This is very important if the equipment has been stored or transported at lower temperatures.

Place the instrument on a stable, flat lab bench which is free of vibrations:

- leave enough space to the rear side of the electronics box, so that the power switch can easily be accessed

Especially when operated without the removable

ground-plate the MCR is very top-heavy and tends to tilt forward easily. Consider fixing the MCR to the table adequately.

To ensure temperature stability and trouble-free measurement, never locate the MCR:

- next to a heating facility
- near an air conditioning, ventilation system or an open window
- in direct sunlight
- Keep the instrument away from vibrations (e.g. caused by other instruments on the same lab bench).
- Keep the instrument away from magnetic fields.
- Read the safety instructions in section 2.

Find all technical data in appendix A.

#### **NOTICE**

Do not remove the transport protection before you have connected a suitable air supply with air quality according to ISO 8573.1, class 1.3.1.

#### **NOTICE**

Always mount the MCR protection tube to protect the coupling and the measuring drive when the MCR is not in use.

## 5.2 Connecting the MCR 702e Space MultiDrive to the Air Supply

For operation the air bearings of the MCR require compressed air. Connect the air supply with a supplied hose to the electronics box air connector (Fig. 3, ④ IN), then connect the air connector of the measuring unit (Fig. 4, ⑦) to the electronics box (Fig. 3, ④ OUT1) using another supplied hose. Make sure that the air supply meets all requirements given in appendix A.

#### **NOTICE**

Never operate the MCR or move the coupling unless you have connected a suitable compressed air supply with the correct pressure. It is good practice to connect the air supply first, before doing anything else with the instrument.



### 5.3 Mounting the Hose Holder

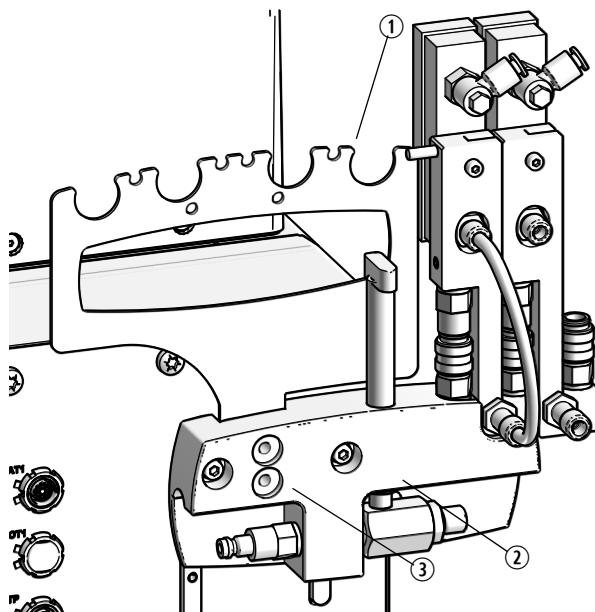

- 1 Hose holder
- 2 Air distributor
- 3 Two screws

Fig. 5: Mounting the hose holder

1. Slide in the hose holder (Fig. 5, ①) from above behind the compressed air distributor (Fig. 5, ②) on the back of the measuring unit.
2. Tighten the two screws (Fig. 5, ③) to fix it.

### 5.4 Connecting the Electronics Box to Power

Connect the mains cable of the MCR (at the back of the electronics box) to a voltage supply that meets the specifications of the MCR (see appendix A). Only use an outlet with protective earth to avoid the risk of an electric shock and use the cables supplied by Anton Paar GmbH.

### 5.5 Connecting the Measuring Unit to the Electronics Box

#### NOTICE

Only connect or disconnect cables when all the devices are turned off.

**Using the cables provided in the connector cables box, connect the following:**

- DAT1 connector of the measuring unit

(Fig. 4, ①) to the DAT1 connector on the electronics box (Fig. 3, ⑤).

- MOT1 connector of the measuring unit (Fig. 4, ②) to the MOT1 connector on the electronics box (Fig. 3, ⑤).
- STP connector of the measuring unit (Fig. 4, ③) to the STP connector on the electronics box (Fig. 3, ⑤).
- PZO connector of the measuring unit (Fig. 4, ④) to the PZO connector on the electronics box (Fig. 3, ⑤).

**Additionally when a lower measuring drive is used:**

- DAT connector of the lower measuring drive to the DAT2 connector on the electronics box (Fig. 3, ⑤).
- MOT1 connector of the lower measuring drive to the MOT2 connector on the electronics box (Fig. 3, ⑤).

### 5.6 Removing the Transport Protection with Reference Movement of the Measuring Head

#### NOTICE

Make sure the air supply is switched on and set to the correct pressure.

#### NOTICE

The air bearing is especially sensitive to side loads, even with connected air pressure. Never press the coupling or a connected measuring system sideways.

1. Switch on the instrument. The main switch is at the back of the electronics box.
2. Wait for the instrument to boot. The boot sequence is finished when the status line of the display at the front of the electronics box shows "Status: O.K.".

#### NOTICE

Do not continue if an error message is displayed. Especially if "NO AIR PRESSURE!" is displayed, check the air supply.

3. Press the button marked "ONLINE" once to switch off the white LED (-> offline).

## 5 Preparing the Instrument



### CAUTION

#### **Moving parts**

There is a risk of body parts being pinched by the moving measuring head. Keep clear of the measuring head while it is moving.

4. Press "Ref". The measuring head will move to the highest position.
5. Remove the transport protection. Please keep the transport protection in case the instrument needs to be moved or shipped later on.
6. Press "ONLINE" again to switch on the white LED (-> online).

### 5.7 Leveling the Instrument

For correct measurements the MCR measuring unit has to be leveled with the adjustable feet:

- To do this, place the supplied water level on the flange ring, align it parallel to the back of the MCR and check if it is leveled (Fig. 6). Level the MCR with the rear adjustable feet (Fig. 2, ⑥).

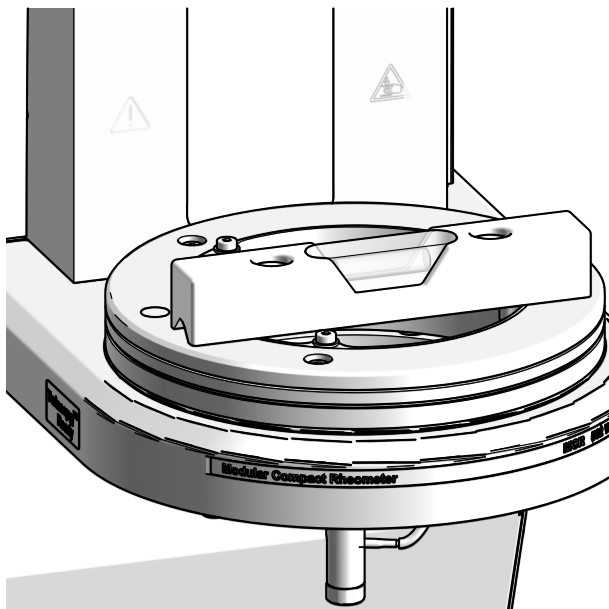

Fig. 6: Water balance parallel to back of instrument

- Turn the water level by 90° so that it lies on the flange ring perpendicular to the back of the MCR and check again if the MCR is leveled (Fig. 7). If you are working in the configuration where the removable ground plate (Fig. 2, ⑨) is

still attached, level the instrument with the ground plate adjustable foot (Fig. 2, ⑩). If the ground plate is removed, level the instrument with the two front adjustable feet (Fig. 2, ⑧).

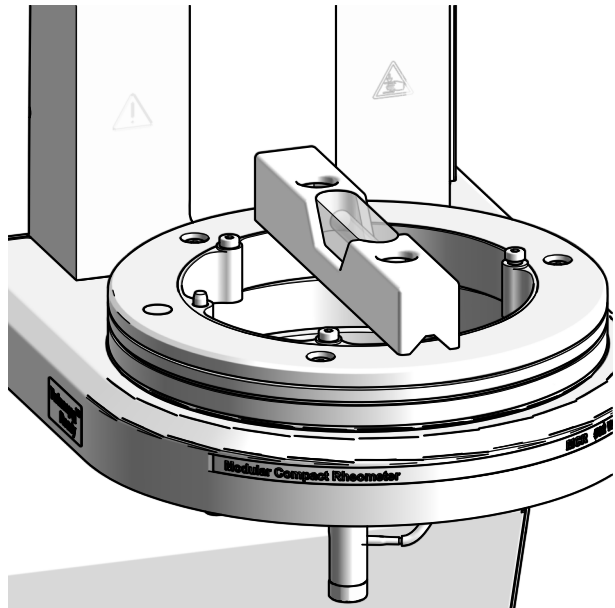

Fig. 7: Water balance perpendicular to back of instrument

#### **NOTICE**

The leveling of the MCR may influence measurements at small torque values. Therefore, check and repeat the leveling regularly. Especially repeat the leveling after moving the instrument.

### 5.8 Connecting a Fluid Circulator

Although a fluid circulator for the measuring drives is not required for operation, we strongly recommend using one. The temperature stabilization of the measuring drives further improves the measuring performance.



### CAUTION

#### **General risk**

Read and observe the safety instructions you will find in the documentation of the accessories used together with the MCR.



### CAUTION

#### **Highly flammable**

Do not use ethanol as coolant. The quick couplings are not sufficiently proof for ethanol.

**NOTICE**

Only use coolants as defined by the manufacturer of the circulator. Also see appendix A for information about the choice of coolant.

**Information:** You need a second fluid circulator for the temperature control of a temperature device or for the counter-cooling of a temperature device. Find the required specifications in the respective instruction manual.

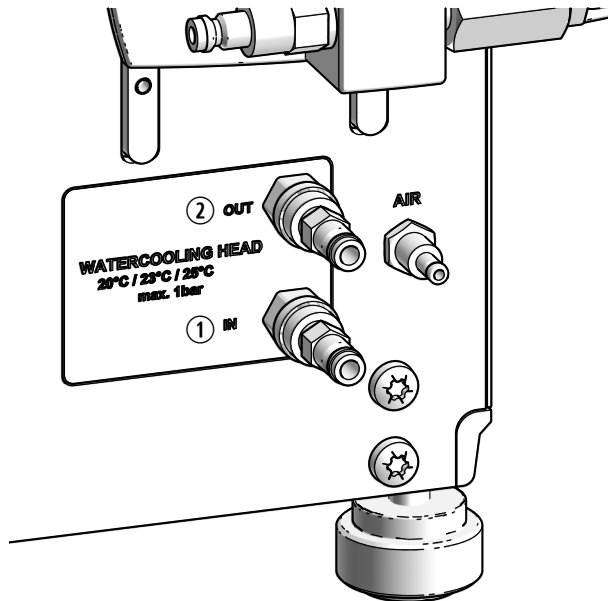

Fig. 8: Hose connections on the measuring unit's rear panel to fluid circulator.

To check if the fluid circulator is working properly and the fluid is circulating, we recommend installing the supplied flow indicators between the fluid circulator and the MCR. Therefore, before you connect the hoses, cut the hose going to "WATERCOOLING HEAD - IN" on the rear panel of the measuring unit at a point where the flow indicator will be clearly visible at all times. Mount the flow indicator between the two hose ends with the supplied hose clamps.

### 5.8.1 Fluid Circulator without Lower Measuring Drive

Connect a suitable separate circulator to control the temperature of the upper measuring drive using the delivered hoses from the accessory kit.

1. Connect the hose from the circulator outlet to the connector "WATERCOOLING HEAD - IN" on the rear panel of the MCR measuring unit (Fig. 8, ①). We recommend installing a flow indicator on this connection.
2. Connect the hose from the circulator inlet to the connector "WATERCOOLING HEAD - OUT" on the rear panel of the MCR (Fig. 8, ②).

If you use a temperature device that requires liquid cooling or counter cooling, connect a second circulator directly to the temperature device.

### 5.8.2 Fluid Circulator with Lower Measuring Drive

When using your MCR in MultiDrive mode, both measuring drives need to be connected to a fluid circulator. To this end, the two measuring drives can be serially mounted onto one single fluid circulator. We recommend proceeding as follows:

1. If applicable, first disconnect the hose stemming from the circulator inlet from the "WATERCOOLING HEAD - OUT" connector on the rear panel of the MCR measuring unit (Fig. 8, ②).
2. Connect the relevant blue fluid hose from the lower measuring drive to the circulator inlet.
3. Extend the second blue hose from the lower measuring drive to reach the connector "WATERCOOLING HEAD - OUT" on the rear panel of the MCR measuring unit (Fig. 8, ②) using the adequate hoses and couplings from the accessory kit.
4. As described in section 5.8.1, connect the hose from the circulator outlet to the connector "WATERCOOLING HEAD - IN" on the rear panel of the MCR measuring unit (Fig. 8, ①). We recommend installing a flow indicator on this connection.

## 5.9 Connecting to the PC

You have two possibilities to connect the MCR to a network or PC. Find the suitable cables in the accessory kit's cables and hoses box:

- MCR USB - PC directly: using the USB cable
- MCR LAN - network: using the standard Ethernet cable

The instrument has to be set to one of these options from the instrument menu. The default setting is USB.

See section 6.4 for details about changing the various settings.

To install the software on the PC, insert the installation USB storage device and follow the instructions you will find on the USB device.

### 5.9.1 Ethernet

Each instrument is equipped with an Ethernet interface. The TCP/IP protocol is used for the communication between software and instrument.

To connect the instrument to the network, use a patch panel connector or an Ethernet switch. The included standard patch cable can be used for the direct connection and for most modern switches. For the direct connection to the PC over Ethernet the crossover patch cable is required.

Connect the patch cable to the connector marked "LAN" (Fig. 3, ②) on the side panel of the instrument and to the network. For the configuration in the software please see the information you will find on the USB storage device you received together with RheoCompass.

#### **NOTICE**

Disable any WLAN connection in the control panel of your PC (it is not sufficient to turn off the WLAN with a switch on the PC). An active WLAN connection might have negative effects on the LAN connection to the MCR.

### 5.9.2 USB

Connect the USB cable to the connector marked "USB" (Fig. 3, ②) at the back of the electronics box. Follow the instruction you will find on the USB storage device you received together with RheoCompass.

## 6 Operating the MCR

### 6.1 Switching on the Instrument

When you have finished connecting all cables and hoses, switch on the MCR with the main power switch situated at the back of the electronics box (Fig. 3, ①).

While the instrument is booting, a progress indicator is shown on the display.

After the MCR has finished the boot procedure and is ready, the following screen is displayed:

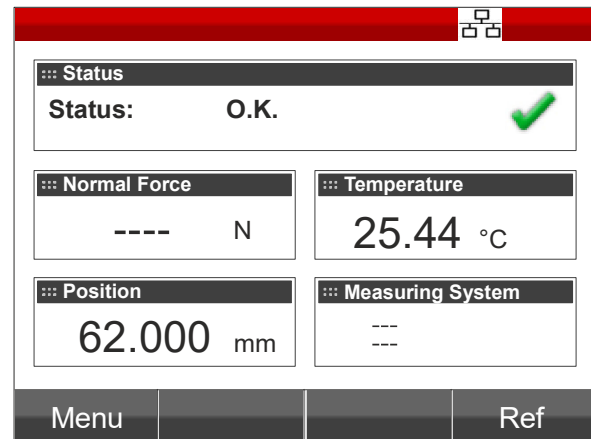

Fig. 9: MCR ready

#### **NOTICE**

Do not continue if an error message is displayed. Especially if "NO AIR PRESSURE!" is displayed, check the air supply.

Physical properties such as normal force, temperature and gap are displayed on the screen.

The bottom line of the screen displays the functions that can be carried out with the respective softkey below.

### 6.2 The MCR Electronics Box Display

Table 5: MCR display

	The top line of the display shows the current connection which can either be Ethernet or USB.
<b>Status</b>	This field displays the current status of the MCR. When selected in the menu (see section 6.4), it also displays the active pressure for the air bearings.
<b>Normal Force</b>	This field displays the normal force acting on the air bearing. When the normal force limit is exceeded, the background of this field turns red. The limit depends on the active moving profile, which is set in RheoCompass.
<b>Temperature</b>	This field displays the current temperature of the temperature device. The background of this field turns red when the temperature device has reached its limits.
<b>Position</b>	This field displays the current measuring gap. The value is calculated from the position of the measuring head and depends on the mounted measuring system and the temperature device. The background of this field turns red when the position of the measuring head has reached its limits.
<b>Measuring System</b>	This field displays the name of the currently mounted measuring systems.

### 6.3 The MCR Operating Panel

The operating panel on the front of the electronics box consists of the display, the four softkeys, the up and down button and the ONLINE button.

The function of the four softkeys may change depending on the current operating state. The relevant function is always displayed in the bottom line of the display.













#### CAUTION

##### **Moving parts**

There is a risk of body parts being pinched by the moving measuring head.

Keep clear of the measuring head while it is moving.

**Table 6: Operating panel button functions**

Button	Description
	With this button you can move the measuring head upwards when the MCR is in offline mode. This button is also used to navigate within the MCR menu.
	With this button you can move the measuring head downwards when the MCR is in offline mode. This button is also used to navigate within the MCR menu.
	With this button you can switch between online and offline mode. When the white LED is on, the MCR is in online mode. In case of an emergency, it can also be used to interrupt any movements of the measuring head, when the MCR is being controlled by the software.
	With this softkey you open the MCR menu.
	With this softkey you can move the measuring head to its reference position.
	With this softkey you can leave the MCR menu without saving any changes.
	This softkey becomes visible when the MCR menu is active. When you press this button the selected setting is opened for editing.
	This softkey becomes visible when the measuring head of the MCR is at the lowest position. With this softkey you can move the measuring head further down to its parking position (see section A).
	After changing settings in the MCR menu, you use this softkey to save and activate the changes.
	With this softkey you can select the value of a setting from a list of available values.
	When a test is running, you can interrupt it with this softkey.

**TIP:** When the MCR is online and remotely controlled by the PC software, the softkey STOP and the button ONLINE can be used to interrupt the remote control and stop any movement of the measuring head in case of an emergency.

When the MCR is controlled by the RheoCompass software, the following additional functions are available on the operating panel:

Table 7: Additional Softkey Buttons with RheoCompass

Button	Description
Init	This softkey starts the initialization of the instrument.
Zero	This softkey starts the determination of the zero gap position.
Adjust	This softkey starts the motor adjustment.
>>	If there are more than 4 softkeys available, you can switch to the next page with this softkey.
<<	With this softkey you can switch back to the previous page.
ToLoad	With this softkey you can move the measuring head to the active load position.
ToWait	With this softkey you can move the measuring head to the active waiting position.
ToMeas	With this softkey you can move the measuring head to the active measuring position.
Motor	After pressing the softkey Adjust, you can start the motor adjustment with this softkey.
Stop	This softkey is used to stop certain actions. Whenever this softkey is available, you can interrupt the current action with this softkey.
Start	With this softkey you can start a test that is prepared by the RheoCompass software.
OK	This softkey is used to confirm certain actions or questions.

## 6.4 MCR Menu

In the MCR menu you will find various settings that you may change as required. All available settings are listed in table 8.

### To change a setting proceed as follows:

1. Press the softkey **Menu**.
2. Use the **▲** and **▼** buttons to select the setting you want to change.
3. Press the softkey **Edit**.
4. Use the **▲** and **▼** buttons to change the value of the setting and press the softkey **Select** to set the value (the changed values do not become active yet).
5. Return to step 2 for any other setting you want to change.
6. When finished amending the settings, press the softkey **Save** to save the new values (now the changes become active) or press **Cancel** to discard the changes.



**Table 8: MCR menu**

Setting	Possible Values	Description
Connection	Ethernet	The connection to the PC running the software is established via Ethernet network
	USB	The connection to the PC running the software is established via USB.
	RS 232	This connection method is reserved for service purposes. Do not use it.
Status Information	OFF	The MCR doesn't show any status information.
	ON	The MCR shows various status information.
	Air Pressure	The MCR shows the air pressure of the air bearings.
Motion Warning	ON OFF	Here you can turn the motion warning on and off. The motion warning sounds an acoustic signal while the measuring head is moving.
Show Temperature	OFF ON	With this setting you can turn the display of the measured temperature on and off. This might be desired when using a value correction in the software and the uncorrected value shall not be displayed.
Error Warning	OFF ON	When this setting is turned OFF, error warnings coming from the software RheoCompass are suppressed.

### 6.5 MCR Maintenance Indicator

The MCR should be maintained and calibrated by qualified service technicians in regular intervals. See section 8. To remind you of this service, the MCR has a built-in maintenance countdown.

From 30 days before the planned maintenance date the MCR will display the number of remaining days in the title line of the MCR display. After the planned

date the maintenance countdown will continue with negative numbers.

The MCR Maintenance Indicator does not affect the performance of the MCR in any way.

The maintenance countdown will be reset by the service technician when the requested maintenance is performed. If you want this service to be performed, please contact your local Anton Paar representative.



*Fig. 10: MCR maintenance indicator*



## 7 Upkeep and Cleaning

Perform the recommended upkeep and cleaning work regularly to ensure the smooth long-term operation of the instrument.

- Where applicable check before and during each measurement that the fluid circulator is working properly and the fluid is circulating. If the flow indicator does not work properly, check that the hose is not dirty or blocked, and check that the circulator is not broken.
- Regularly check the hose connections to the MCR. They should not be bent or blocked.
- Regularly check that the supplied air is clean, dry and oil-free, and that the compressed air supply unit meets all necessary requirements (Appendix A: Technical Data). For details see the documentation of the filter system.
- Always handle the measuring system with care. Even minor damage may cause serious measurement errors. Never use force when you remove the measuring system from the sample or when you wipe sample off the measuring system.
- We recommend a maintenance contract. See section 8 for more information about maintenance. Please contact our local representative for details.

### 7.1 Cleaning and Drying the Measuring Cells

- Wipe off the MCR with a dry or slightly damp, lint-free cloth. A mild detergent may be used if necessary. Do not scratch the surface.
- Find a list of all wetted materials below.
- Keep the MCR couplings clean. Do not oil or grease the coupling.
- Use cotton buds and Ethanol to clean the inner surface of the coupling. Take care not to damage the transponder contact in the center of the

coupling.

- If the sleeve of the coupling is jammed, you can try dripping some Ethanol between the sleeve and the rest of the coupling (see Fig. 11). Don't use any other solvents; some models of the coupling have an NBR O-ring inside that might get damaged. Then move the sleeve up and down until it runs smoothly. Dry the coupling with a lint-free cloth.

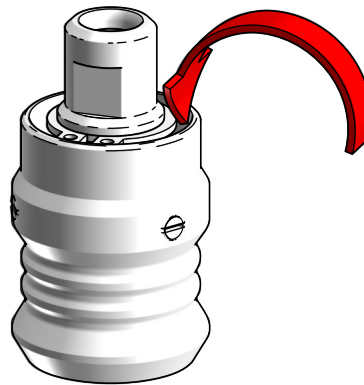

Fig. 11: Dripping solvent into the coupling

### 7.2 Wetted Parts

The following materials are in contact with samples and the cleaning liquids:

**Table 9: Sample and Solvent Wetted Parts**

Material	Description
Stainless Steel (standard)	1.4404 or 1.4418
Titanium	Titanium Grade 5, DIN 3.7165
Hastelloy	Hastelloy C276, DIN 2.4819
Quartz Glass (QGL)	Quartz glass Suprasil
Glass (GL)	Borosilicate 3.3

### 7.3 Storing and Transporting the Instrument

If the MCR is taken out of operation for a longer time period or if you have to send it back for some reason or transport it, the measuring head and especially the air bearing have to be secured in a special way.



**CAUTION**

**Moving parts**

There is a risk of body parts being pinched by the moving measuring head. Keep clear of the measuring head while it is moving.

**NOTICE**

Do not turn off the air supply, before the transport protection is applied and the measuring head is in the parking position.

1. Remove all temperature devices and measuring systems.
2. Place the transport protection on the center of the temperature device flange with the gray foam rubber facing upwards.
3. If the MCR is in online mode, press "ONLINE" and switch the MCR to offline mode (white LED is off).
4. Use the downward arrow to move the measuring head to its lowest position.

When the measuring head reaches the lowest position, the softkey "Park" becomes available.

5. Press "Park" and the measuring head will move down even further.  
  
When the position display changes to "---.--- mm", the parking position is reached.
6. Now you can turn off the instrument and disconnect the air supply.
7. Disconnect the cooling water supply and drain the pipes.

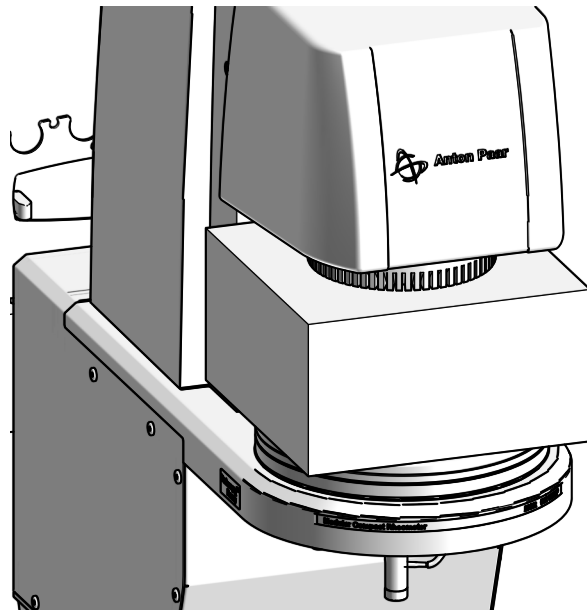

Fig. 12: MCR with transport protection

### 7.4 Packing the Instrument for Transport

This instruction shows you how to pack an MCR of the xx2e series for transport.

**NOTICE**

Please note that the instructions must be carried out carefully, as failures can result in serious damage to the MCR.

For questions or in case of uncertainty regarding the instruction for packing an MCR 702e Space MultiDrive please contact your local distributor or Anton Paar GmbH directly.

**Supplied Accessories**

If you didn't keep the packing material the MCR originally was delivered in, you will need the following items to pack an MCR 702e Space MultiDrive for transportation:

- p/n 102149: Transport protection for MCR xx2e measuring head
- p/n 76428: Desiccant bag DESI PAK®, 4 DIN units = 125 g
- p/n 18453: SG-Bag, transparent, 670/450x1100x0.10 mm
- p/n 98947: Two-way pallet
- p/n 98696: Cardboard box, 850x580x680 cm

- p/n 98695: Packing foam material for MCR xx2e
- p/n 188726: Packing foam

Additionally, you will need adhesive packing tape as well as packing clamps and/or transport straps.

#### Packing for Transportation:



#### CAUTION

##### **Moving parts.**

There is a risk of body parts being pinched by the moving measuring head. Keep clear of the measuring head while it is moving.

#### NOTICE

Do not turn off the air supply before the transport protection is applied and the measuring head is in the parking position.

1. Prepare the instrument as described in section 7.3.
2. Fix a desiccant bag (p/n 76428) to the front of the transport protection with adhesive tape.
3. Wrap the instrument with the SG-Bag (p/n 18453). Close the bag tightly with adhesive tape.



#### CAUTION

##### **Heavy object**

The MCR is heavy (up to 60 kg with accessories), therefore adequate lifting by two persons is required to prevent injuries and instrument damage. Never lift the MCR by its head. There are recessed grips at the bottom of the instrument (Fig. 2, ⑥), which should always be used to lift the MCR.

#### NOTICE

The MCR should never be lifted by its head. Use the recessed grips at the rear side and underneath the front of the instrument.

4. Place the bottom part of the cardboard box (p/n 98696) onto the two-way pallet (p/n 98947) and insert one half of the protection foam (p/n 98695).
5. If you are using the original packing material skip the next step and continue at step 7.
6. Break out all the parts of the protection foam indicated in Fig. 14:
7. Carefully place the MCR onto the packing foam.
8. Put the two packing foam pieces (p/n 188726) in place. Take care that they are aligned with the edges of the other packing material - left and



Fig. 13: Lower part of cardboard box and protection foam

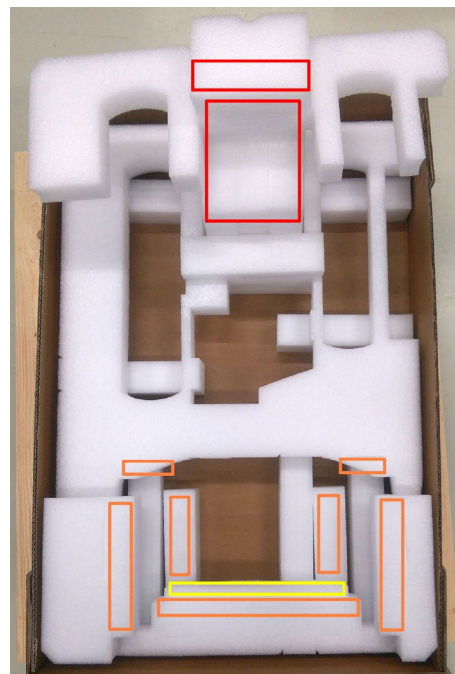

Fig. 14: Lower packing foam break outs

right are not identical (see Fig. 15).



*Fig. 15: Additional packing material for MCR 702e Space MultiDrive*

9. Put the accessory kits and the documentation folder in their place.
10. If you are using the original packing material skip the next step and continue at step 12.
11. Remove the parts of the upper packing foam indicated in green in Fig. 16.

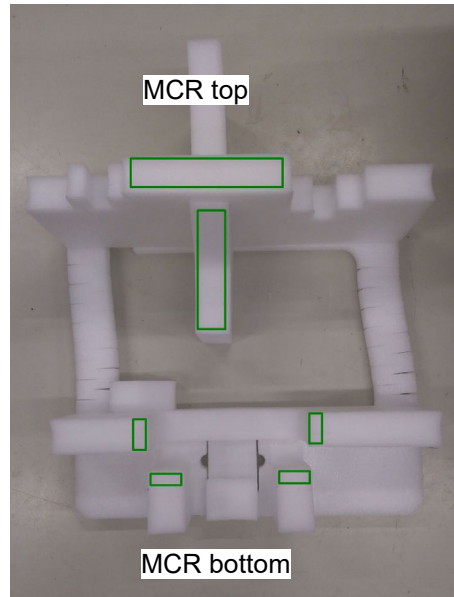

*Fig. 16: Upper packing foam break outs*

12. Turn the upper packing foam over and put it onto the MCR.
13. Close the box with adhesive tape and packing clamps. Fasten the box to the two-way pallet with transport straps.

The MCR 702e Space MultiDrive is now ready for transportation.

## 8 Maintenance and Repair

### 8.1 Maintenance Performed by an Authorized Anton Paar Service Engineer

The MCR 702e Space MultiDrive requires periodic maintenance which shall be performed by an authorized Anton Paar Service Engineer. <sup>1</sup>

A missing maintenance may mean that under certain conditions your warranty is no longer valid. <sup>2</sup>

#### Maintenance Interval:

- Any air filter should be serviced once per year.
- Coolant connections should be serviced at least every 24 months.
- Adjustments and calibrations of both mechanical and electronic parts of the rheometer setup should be performed once per year.
- Depending on your MCR's configuration, various maintenance kits are available, which are selected by the service technician.

**The following parts are generally excluded from the warranty (wear and tear parts):**

- Cooling liquids
- Filters
- Fuses
- Glass parts
- Hoses
- Lubricants
- O-Rings
- Parts of maintenance kits
- Seals and gaskets

### 8.2 Repair Performed by an Authorized Anton Paar Representative

In case your instrument needs repair, contact your local Anton Paar representative, who will take care of the necessary steps. If your instrument needs to be returned, request an RMA (Return Material Authorization Number). It must not be sent without the RMA and the filled "Safety Declaration for Instrument Repairs". Please make sure it is cleaned before return.

**TIP:** Find the contact data of your local Anton Paar representative on the Anton Paar website (<http://www.anton-paar.com>) under "Contact".

<sup>1</sup> Please contact your Anton Paar representative to get an offer.

<sup>2</sup> For detailed information please see the general terms of delivery (GTD) on the Anton Paar website (<http://www.anton-paar.com>).

# Appendix A: Technical Data

## Appendix A.1: Technical Data MCR 702e Space MultiDrive

**Table 10: Technical Data and Specifications**

Property	MCR 702e Space MultiDrive
<b>Environmental Conditions (EN61010):</b>	see appendix A.2 for atmospheres other than air
Temperature	+15 °C to +35 °C, recommended 23 °C to ±3 °C
Humidity	10 to 80 % relative humidity, non-condensing
Overvoltage category	II
Degree of pollution	2
Radiated emissions	Class A. This equipment can generate radiated disturbances in residential environment
Atmosphere	Air, Argon, Nitrogen
Airborne Noise Emission	< 70 dB (A)
<b>Dimension:</b>	
Weight of measuring unit	approximately 50 kg
Weight of electronics box	14.3 kg
Size of measuring unit (W x H x D)	262 mm x 754 mm x 554 mm
Size of electronics box (W x H x D)	330 mm x 231 mm x 515 mm
<b>Air/Gas Supply:</b>	
Quality	Clean, dry and oil-free (ISO 8573.1, class 1.3.1)
Air pressure	6 bar recommended (min. 5 bar, max. 10 bar)
Air consumption average	2.4 m <sup>3</sup> <sub>N</sub> /h (MCR without any accessories) 5.4 m <sup>3</sup> <sub>N</sub> /h (complete system in operation)
<b>Power supply:</b>	Grounded 16 A power socket is mandatory. Protection class I (IEC 61140)
Voltage	AC 100 to 240 V
Frequency	50 to 60 Hz
Power consumption	900 W
Fuse	T10 AH
<b>Computer:</b>	See the information you will find on the USB storage device you received together with RheoCompass



**Table 10: Technical Data and Specifications**

Property	MCR 702e Space MultiDrive
<b>Water-cooling head:</b>	
Temperature	constant at a value between 15 °C and 35 °C recommended 20 °C, 23 °C or 25 °C and as close to ambient temperature as possible
Maximum pressure	constant at 1 bar
Flow rate	0.4 L/min to 0.7 L/min
<b>Circulator:</b>	
Temperature	-20 °C to +70 °C
Flow rate	0.4 L/min to 0.7 L/min
Maximum pressure	1 bar
Coolant	Mixture of 60 % distilled, deionized or bottled drinking water and 40 % concentrate of engine coolant antifreeze with corrosion protection. Water must not contain chlorine or added minerals. The use of pure distilled or deionized water is not permitted. Recommended coolants with corrosion protection are BASF G30, G40 and G48 or equivalent products of other suppliers. Do NOT use ethanol as a coolant.

**Table 11: Specifications**

	Unit	MCR 702e Space MultiDrive
Bearing		Air
Min. torque rotation	nNm	1
Min. torque oscillation	nNm	0.5
Max. torque	mNm	230
Deflection angle	μrad	0.05 to ∞
Max. speed	rad/s	314
Min. frequency	rad/s	10 <sup>-7</sup>
Max. frequency	rad/s	628
Normal force range	N	0.005 to 50
Normal force resolution	mN	0.5

## Appendix A.2: Operation in a Glove-box



### CAUTION

#### **High voltage**

When the MCR is operated in an Argon atmosphere, the piezo elements are deactivated or removed. They must not be re-activated.

### NOTICE

#### **Risk of damaging the device**

Ignoring the following points might lead to damage of the device.

### NOTICE

#### **Risk of losing warranty**

Ignoring the following points might lead to loss of warranty.

The following points have to be considered when operating the MCR 702e Space inside a glove-box:

- The electronics box of the MCR 702e Space and all other components, which are directly supplied with mains voltage, must be placed outside the glove-box.
- The glove-box must be actively cooled and the temperature inside the glove-box must not exceed 30 °C.

- The pressure inside the glove-box and the air-lock must not drop substantially below ambient pressure.
- The IsoLign flange is deactivated by the manufacturer and must not be connected. The piezo elements are removed.
- No atmospheres other than Argon, Nitrogen or air are allowed.
- Follow the local regulations concerning operation with gases.
- Take notice of the safety instructions of the glove-box.
- The MCR 702e Space must be set up properly inside the glove-box, see section 5.1.
- Take into account that the air bearings of the measuring drives are supplied with compressed gas. Argon, Nitrogen or air may be used, if they fulfill the specifications (see appendix A.1).
- Please check with the manufacturer whether accessories (temperature devices etc.) you want use with the MCR 702e Space inside the glove-box are suitable for this application.
- Please contact your Anton Paar representative for further clarification and technical support.

## Appendix A.3: Pin Assignments

All images of connectors show the view from outside the MCR.

**Table 12: Pt100**

	Pin	Pt100	Description
	1	Pt100+	
	2	Pt100_Sig+	
	3	Pt100_Sig-	
	4	Pt100-	



Table 13: Serial Interface COM

	Pin	Name	Description
	1	N.C.	not connected
	2	RXD	
	3	TXD	
	4	N.C.	not connected
	5	W-	
	6	N.C.	not connected
	7	RTS	
	8	CTS	
	9	W+	

Table 14: Thermo Couple



	Pin	TC	Description
	1	TC_Sig +	
	2	TC_Sig -	

Table 15: Analog outputs A1 to A4

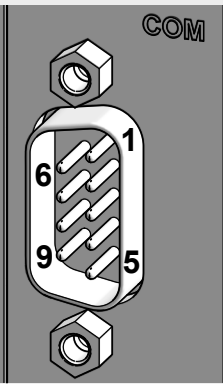
	Pin	Name	Description
	inner	analog signal	Analog representation of a value as voltage between -10 V and +10 V.
	outer	GND	Signal ground
<b>Specifications:</b>			
Output type			ground referred
Output voltage			±10 V
Max. output current			±10 mA
Max. capacitive load			820 pF
Resolution			0.305 mV
Accuracy			±10 mV (theoretically < 2.5 mV)
Output short circuit duration			indefinite

**NOTICE**

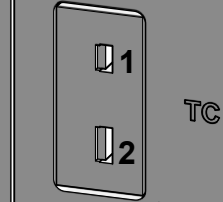
All devices connected to the AUX or POWER/FMU connector must be equipped with flyback diodes.

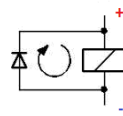

**Table 16: AUX1 and AUX2**

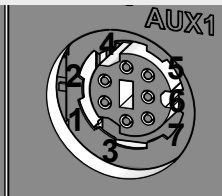
	Pin	Name	Description
	1	RGND	Remote GND
	2	RSW2	Relay switch 1
	3	R+	Remote +
	4	RSW1	Relay switch 2
	5	AIN-	Analog IN-
	6	AIN+	Analog IN+
	7	N.C.	not connected
	<b>Specifications:</b>		
	Input type		differential
	Differential input voltage		±10 V
	Absolute maximum input voltage		±30 V (any pin to GND, no damage)
	Differential input resistance		10 MΩ    10 pF
	Common mode input resistance		100 KΩ
	Common mode input voltage		±7 V
	Resolution		0.305 mV
	Accuracy		±10 mV (theoretical < 2.5 mV)
	Max. current relay contact		2 A DC / AC (ohmic load)
	Max. voltage relay contact		38 V DC, 30 V AC (ohmic load)
	Voltage supply		25 V DC ±5 %
	Max current long term		300 mA
	Output short circuit duration		indefinite

# Appendix B: Declaration of Conformity

## EC Declaration of Conformity

(original)



The manufacturer **Anton Paar GmbH**, Anton-Paar-Str. 20, A-8054 Graz, Austria – Europe, hereby declares that the machinery described below:

Description: **Modular Compact Rheometer**

Model: **MCR 702e Space**

Material number: 241357

Serial number: .....

complies with all the relevant provisions of the **Machinery Directive (2006/42/EC, OJ L 157/24 of 9.6.2006)** and the regulations transposing it into national law

complies with all the relevant provisions of the **Electromagnetic Compatibility Directive (2014/30/EU, OJ L 96/79 of 29.3.2014)**

complies with all the safety objectives of the **Low Voltage Directive (2014/35/EU, OJ L 96/357 of 29.3.2014)**

complies with all the relevant provisions of the **RoHS Directive (2011/65/EU, OJ L 174/88 of 1.7.2011)**

complies with the provisions of the following harmonized standards:

- EN ISO 12100:2010 Safety of machinery - General principles for design - Risk assessment and risk reduction
- EN 61326-1:2013 Electrical equipment for measurement, control and laboratory use - EMC requirements - Part 1: General requirements

The product is classified as a class A equipment and is not intended for the use in industrial area.

complies with the provisions of the following technical standards:

- EN 61010-1:2010 +A1:2019 Safety requirements for electrical equipment for measurement, control and laboratory use - Part 1: General requirements

This declaration relates exclusively to the machinery in the state in which it was placed on the market, and excludes components which are added and/or operations carried out subsequently by the final user.

The manufacturer compiles the technical file according to 2006/42/EC Annex II

Done at Graz, 2022-07-08

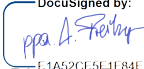
DocuSigned by:  
  
 DI Alfred Freiburger  
 Executive Director  
 Business Unit Characterization

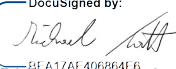
DocuSigned by:  
  
 DI Dr. mont. Michael Toifl  
 Head of Rheometry  
 Business Unit Characterization

## UK Declaration of Conformity



The manufacturer **Anton Paar GmbH**, Anton-Paar-Str. 20, A-8054 Graz, Austria – Europe, hereby declares that the machinery described below:

Description: **Modular Compact Rheometer**  
Model: **MCR 702e Space**  
Material number: 241357  
Serial number: .....

is in conformity with all the relevant UK legislation

**Supply of Machinery (Safety) Regulations 2008, 2008 No. 1597**

**Electromagnetic Compatibility Regulations 2016, 2016 No. 1091**

**Restriction of the Use of Certain Hazardous Substances in Electrical and Electronic Equipment Regulations 2012, 2012 No. 3032**

is in conformity with all the UK safety objectives of the

**Electrical Equipment (Safety) Regulations 2016, 2016 No. 1101**

complies with the designated standards:

- EN ISO 12100:2010
- EN 61010-1:2010 +A1:2019 +A1:2019/AC:2019
- EN 61326-1:2013

This declaration of conformity is issued under the sole responsibility of the manufacturer.

Importer: Anton Paar Ltd, Unit F, The Courtyard, Hatfield Rd, St Albans AL4 0LA, United Kingdom;

Place and date of issue: Graz, 2022-07-08

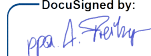
DocuSigned by:  
  
DI Alfred Freiburger  
Executive Director  
Business Unit Characterization

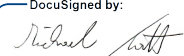
DocuSigned by:  
  
DI Dr. mont. Michael Toifl  
Head of Rheometry  
Business Unit Characterization